

# رالي عسير rallyaseer 2022

22<sup>nd</sup> – 24<sup>th</sup> September 2022

Supplementary Regulations

**AUTO**

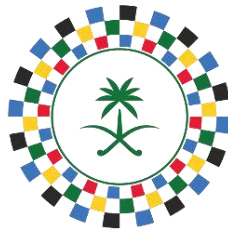

الاتحاد السعودي للسيارات والدراجات النارية  
Saudi Automobile & Motorcycle Federation

1.	INTRODUCTION .....	5
1.1	<b>PREAMBLE</b> .....	5
1.2	<b>OVERALL NUMBERS, DISTANCES OF SS'S AND TOTAL DISTANCE OF THE ITINERARY</b> .....	5
1.3	<b>AVERAGE ALTITUDE</b> .....	5
1.4	<b>ROUTE TERRAIN ON SELECTIVE SECTIONS</b> .....	6
2	ORGANISATION.....	6
2.1	TITLES FOR WHICH THE RALLY COUNTS:.....	6
2.2	APPROVALS, ASN VISA DETAILS .....	6
2.3	ORGANISER'S NAME, ADDRESS, & CONTACT DETAILS.....	6
2.4	ORGANISING COMMITTEE .....	6
2.5	STEWARDS OF THE MEETING.....	6
2.6	DELEGATES AND OBSERVER .....	6
2.7	SENIOR OFFICIALS.....	7
2.8	LOCATION OF THE RALLY HEADQUARTERS & CONTACT DETAILS:.....	7
3	PROGRAMME IN CHRONOLOGICAL ORDER & LOCATIONS.....	9
4	ENTRIES.....	11
4.1	OPENING AND CLOSING DATES FOR ENTRIES: .....	11
4.2	ENTRY PROCEDURE .....	11
4.3	NUMBER OF ENTRANTS ACCEPTED AND VEHICLE CLASSES .....	12
4.4	ACCEPTED GROUPS / CLASSES.....	12
4.5	ENTRY FEES AND PACKAGES.....	13
4.6	LOCAL SUPPORT PACKAGE.....	14
4.7	INTERNATIONAL SUPPORT PACKAGE.....	14
4.8	PAYMENT DETAILS .....	14
4.9	ENTRY FEE REFUND.....	15
5	INSURANCE COVER .....	15
5.1	THIRD PARTY INSURANCE: .....	15
5.2	INSURANCE COMPANY:.....	15
5.3	EXCLUSION: .....	15
5.4	ORGANISERS LIABILITY: .....	15
5.5	ADDITIONAL INSURANCE: .....	15
5.6	PROOF OF INSURANCE: .....	15
5.7	IN CASE OF ACCIDENT:.....	16
6	ADVERTISING & IDENTIFICATION.....	16
6.1	OBLIGATORY ORGANISER'S ADVERTISING.....	16
6.2	OPTIONAL ORGANISER'S ADVERTISING .....	16
6.3	DRIVER'S & CO-DRIVER'S NAMES & IDENTIFICATION .....	16
6.4	RESTRICTIONS ON ADVERTISING.....	16
6.5	NATIONAL RESTRICTIONS ON ADVERTISING .....	16
6.6	BREACH OF REGULATIONS.....	17
7	TYRES.....	17
7.1	REGULATIONS REGARDING TYRES.....	17
7.2	NUMBER OF TYRES.....	17

8	FUEL .....	17
8.1	TECHNICAL REQUIREMENTS & COMPLIANCE .....	17
9	ADMINISTRATIVE CHECKS.....	17
9.1	DOCUMENTS TO BE PRESENTED .....	17
9.2	TIMETABLE .....	18
9.3	LOCATION: .....	18
10	SCRUTINEERING, SEALING & MARKING.....	18
10.1	VENUE & TIMETABLE.....	18
10.2	MANDATORY DOCUMENTS.....	18
10.3	MUD FLAPS.....	18
10.4	DRIVER'S SAFETY EQUIPMENT.....	19
10.5	NECESSARY TECHNICAL INSTALLATIONS .....	19
10.6	ON BOARD CAMERAS .....	20
10.7	ELECTRONIC EQUIPMENT.....	20
10.8	WINDSCREEN:.....	20
11	OTHER PROCEDURES .....	20
11.1	OFFICIAL TIME USED DURING THE EVENT .....	20
11.2	DRIVERS BRIEFING .....	20
11.3	PRE START AREA .....	20
11.4	RALLY ASEER CEREMONIAL START PROCEDURE & ORDER .....	21
11.5	ELECTRONIC START PROCEDURE AT SELECTIVE SECTIONS .....	21
11.6	START OF THE RALLY.....	21
11.7	RUNNING OF THE RALLY .....	21
11.8	FINISH PROCEDURE.....	23
11.9	CLASSIFICATION.....	23
11.10	SAFETY, NAVIGATION & TRACKING EQUIPMENT .....	23
11.11	"VEHICLE TO VEHICLE ALARM SYSTEM" ARTICLE 48.3 OF THE FIA 2022 (CCRSR) .....	23
11.12	ASSISTANCE IN CASE OF ACCIDENT: ARTICLE 48.4 OF THE FIA 2022 (CCRSR) .....	24
11.13	QUALIFYING STAGE .....	24
11.14	SHAKEDOWN .....	24
11.15	SUPER SPECIAL STAGE REGULATIONS & ORDER .....	24
11.16	PERMITTED EARLY CHECK IN .....	24
11.17	ROAD BOOK DELIVERY .....	24
11.18	SERVICING OF VEHICLES .....	24
12	IDENTIFICATION OF THE OFFICIALS & MARSHALS .....	28
13	PRIZES .....	29
13.1	PODIUM / PRIZE GIVING .....	29
13.2	PRIZES .....	29
14	FINAL CHECKS, PROTESTS & APPEALS & FINES .....	30
14.1	FINAL CHECKS .....	30
14.2	PROTEST DEPOSIT .....	30
14.3	APPEAL DEPOSIT.....	30
14.4	PAYMENT OF FINES / PROTEST DEPOSIT .....	30

15	APPENDIX 1 – ITINERARY .....	31
16	APPENDIX 2 – COMPETITORS' RELATIONS OFFICERS .....	32
16.1	COMPETITORS' RELATIONS OFFICERS.....	32
16.2	CRO'S SCHEDULE .....	32
17	APPENDIX 3 – DECALS & POSITIONS OF SUPPLEMENTARY ADVERTISING .....	33
17.1	COMPETITION NUMBERS .....	33
17.2	EVENT PLATES.....	33
18	APPENDIX 4 – FIA ISC APPENDIX L EXTRACTS .....	34
19	APPENDIX 5 – INSTRUCTIONS FOR USING TRACKING/NAVIGATION DEVICE .....	35
20	APPENDIX 6 – NAVIGATION DEVICE INSTALLATION MANUAL .....	46
1.	<b>POWER CORD</b> .....	47
2.	<b>BASE/MOUNT</b> .....	47
3.	<b>GPS ANTENNA</b> .....	48
4.	<b>ANTENNA IRIDIUM</b> .....	48
5.	<b>RF ANTENNA</b> .....	48
21	APPENDIX 7 – START LIGHT PROCEDURE .....	51
22	APPENDIX 8 – EQUIPMENT & SAFETY .....	52
22.1	MEDICAL EQUIPMENT - APPENDIX III ART. 1 OF THE 2022 FIA (CCRSR).....	52
22.2	MEDICATION - INFORMATION.....	52
22.3	COMPULSORY: A SEALED AND VALID MEDICAL KIT IN ACCORDANCE WITH THE SPECIFICATION FOR CROSS COUNTRY (FIA TECHNICAL LIST N°83) MUST BE PLACED INSIDE THE COCKPIT. ....	52
22.4	SURVIVAL EQUIPMENT - APPENDIX III ART. 2 OF THE 2022 FIA (CCRSR) .....	53
22.5	ORGANIZER SAFETY MEASURES .....	53
23	APPENDIX 9 – SUMMARY OF PENALTIES .....	54
24	APPENDIX 10 – DIGITAL OFFICIAL NOTICE BOARD – SPORTITY .....	57

## 1. INTRODUCTION

Name of event	Date of event
Aseer Rally 2022	22 <sup>nd</sup> till 24 <sup>th</sup> September 2022

### 1.1 Preamble

The "Aseer Rally 2022" rally will be run in compliance with:

- 2022 FIA International Sporting Code and its appendices (hereinafter the ISC)
- 2022 FIA Cross Country Rallies Sporting Regulations and its appendices (CCRSR).
- National Regulations, which comply with the FIA Regulations
- These Supplementary Regulations (hereinafter the SR)
- National Traffic Laws in KSA.

Modifications, amendments and/or changes to these Supplementary Regulations shall be made in the form of numbered and dated Bulletins. Bulletins will be issued by the Organiser, up to the commencement of administrative checks with the approval of the ASN, after the administrative checks by the Stewards of the Meeting. Exceptionally, modifications to the itinerary may be made by the Organiser / COC.

*If The Rally will be twinned with Motorcycles which is not likely to happen. Therefore, the required interval of 30 minutes (except for the Super Special Stage – SSS1) will be observed. The conditions of the motorcycle competition are set out in separate Supplementary Regulations.*

Unless specifically covered within these Supplementary Regulations, the text of the 2022 FIA Cross Country Rallies Sporting Regulations (CCRSR) and its appendices applies and should be referred to.

All FIA regulations can be found at <https://www.fia.com/regulations>. All Documents will be written only in English, & The English version will be binding for Aseer Rally 2022.

### Length of Selective Sections

Leg 1:	155.02 km
Leg 2:	155.01 km

### 1.2 Overall Numbers, distances of SS's and total distance of the itinerary

Number of Legs:	2
Number of Sections:	2
Number of Selective Sections:	4
Total distance of the itinerary:	769.10 km
Overall length of Selective Sections:	310.03 km

### 1.3 Average Altitude

The altitude for the selective sections is:

Stage	Alt.(m) @ Start	Average Alt (m)	Lowest Alt (m)	Highest Alt (m)
SS 1A Al Ghadah	1685	1625	1474	1803
SS 1B Al Qa'Ah 1	1960	2000	1960	2071
SS 2A Tareeb	1685	1625	1474	1803
SS 2B Al Qa'Ah 2	1960	2000	1960	2071

Maximum Slope: 2.8% / -5.4%

Avg slope: 0.7% / -0.7%

## 1.4 Route Terrain on Selective Sections

The Rally will be run on Sand and rocky desert routes.

	SS 1A & SS 2A	SS 1B & SS 2B
Solid Ground / (Dusty B)	50%	40%
Lose Wadi & Twisty	30%	20%
Rough Rocks / Stones	20%	20%
Lose Dusty Ground	0%	20%

Leg 1 Safety Type A

Leg 2 Safety Type A

## 2 ORGANISATION

### 2.1 Titles for which the rally counts:

- 2022 Saudi TOYOTA Rally Championship

### 2.2 Approvals, ASN Visa Details

- ASN Visa No.: NR-001 Issued on: 8<sup>th</sup>, of September 2022

### 2.3 Organiser's Name, Address, & Contact Details

Saudi Auto Automobile & Motorcycle Federation

Contacts:

Tel.: +966 (11) 880 4614

Fax: +966 (11) 880 4661

Email: [info@samf.gov.sa](mailto:info@samf.gov.sa)

Web: [www.saudi-championship.com/asir-rally](http://www.saudi-championship.com/asir-rally) & [www.samf.gov.sa](http://www.samf.gov.sa)

### 2.4 Organising Committee

- Chairman: HRH Prince Khalid Bin Sultan
- Member Sattam Alhomazi
- Member Elie Samaan
- Member Abdullah Bakhshab

### 2.5 Stewards of the Meeting

Title	Name
Chairman of Stewards:	Elie SAMAAN
Steward	Ahmed JAN
Steward	Hasan AL ABDALI

- Secretary to the Stewards: Mazen Dajani License #: 2022/OI/038

### 2.6 Delegates and Observer

- ASN Observer N/A

## 2.7 Senior Officials

Title	Name	Licence No.
Rally Manager	Elie Semaan	
Deputy Rally Manager	Ahmad Jan	
Clerk of the Course	Khaled Zakaria	2022/OI/003
Deputy Clerk of the Course	Amer Alnahdi	
Chief Safety Officer	AbdelAziz Al Khulaifi	
Safety Officer	Mousa Hazineh	2022/OI/005
Assistant COC – Field	Ibrahim Sheikh	2022/OI/013
Rout Manager	Laszlo Polgar	
Crews Relations Officer CRO	Samer Hejazi	
Chief Scrutineer	Nedal Bin Salman	
Scrutineer	Ali Alhmood	
Scrutineer	Abdulaziz Rafea	
Chief Marshal	Abdul-Rahman Qahtani	
Assistant chief marshal	Abdullah Sulaiman Alfahhad	
Chief Medical Officer	Dr. Ahad Al Saud	
Service Park Manager	Mansour Al Johar	
Secretary of the Rally	Abdulaziz Alkamel	
Administrative Checks Officers	Abdulaziz Alkamel / Yaman Abu Al Adas	2022/OI/030
Media Officer	Walid Qaranuh	
Tracking Officer	Marcos Alejandro / Stella	
Chief Results	Balazs Toth / Chronomoto	
Timekeepers	Istvan Polgar / Chronomoto	
Registration & Logistics Officer	Ahmed Ramadan	
Registration & Logistics Officer	Moslet Alsubaie	
Registration & Logistics Officer	Adulaziz Alkamel	

All the Senior Officials mentioned above as well as all the Marshals in the field are considered Judges of Fact.

## 2.8 Location of the Rally Headquarters & Contact details:

2.8.1 Rally HQ will be operational from Wednesday, September 21<sup>st</sup>, 2022 @ 07:00 till Saturday September 24<sup>th</sup>, 2022 @20:00

Location: Abha palace hotel – فندق قصر ابها  
Tel.: +966 55 308 8099  
+966 17 229 4444  
Email: info@samf.gov.sa  
GPS: N 18°12.602 E 42°28.987

2.8.2 Rally Aseer 2022 **EMERGENCY NUMBER** during the event:

**Tel: +966 55 955 7661**

2.8.3 Service Park Will Open:

Fully operational	Wednesday, September 21 <sup>st</sup> , 2022	06:30h
-------------------	--	--------

2.8.4 Service Park Will Close on Sunday, September 25<sup>th</sup>, 2022 @ 14:00h

2.8.5 Service Park & Parc Fermé Location: Aseer HQ – Abha palace hotel N 18°12.602 E 42°28.987

2.8.6 Digital Official Notice Board: Sportity App links [iOS](#), [Android](#), password: ASEER22 Please note that **NO** physical Notice Board is used, all the information will be available on Sportity. & [www.saudi-championship.com/asir-rally](http://www.saudi-championship.com/asir-rally)

Ceremonial Start & Finish Entrance Location: Sama Abha Parks- Abha N 18°1428.13 E 42°2858.34



### 3 PROGRAMME IN CHRONOLOGICAL ORDER & LOCATIONS

All times are in local time, local time is GMT +3. Official time is GPS time.

Wednesday, August 31 <sup>st</sup> , 2022		
10:00h	Opening date for entries	
Saturday, September 17 <sup>th</sup> , 2022		
12:00h	Closing date for entries Co Driver Details Submission Closing date to order extra space in service park	
Monday, September 19 <sup>th</sup> , 2022		
20:00h	Publication of entry list	Sportity - Website
20:00h	Publication of Administrative Checks & Scrutineering Time Table	Sportity - Website
Wednesday, September 21 <sup>st</sup> , 2022		
06:30h	Service park open	Aseer HQ – Abha palace hotel
07:00h-20:00h	Rally office open	Aseer HQ – Abha palace hotel
10:00h-20:00h	Media center open / Media accreditation	Aseer HQ – Abha palace hotel
07:00h-19:00h	Administrative checks, collection of materials, documents & Tracking/Navigation Devices	Aseer HQ – Abha palace hotel
07:30h- 20:00h	Scrutineering – Sealing & marking of components, at Scrutineering venue	Service Park – Abha palace hotel
20:30h	Driver's Briefing	Aseer HQ – Abha palace hotel
Thursday, September 22 <sup>nd</sup>		
07:00h-20:00h	Rally office open	Aseer HQ – Abha palace hotel
08:00h-20:00h	Media center open	Aseer HQ – Abha palace hotel
14:00h-15:30h	Re-Scrutineering for vehicles which did not pass – Scrutineering venue	Service Park – Abha palace hotel
16:30h	Publication of the start list for Ceremonial Start, and the list of competitors eligible to start	Sportity - Website
17:00h	Publication of start list for Leg 1	Sportity - Website
17:00h-18:00h	Pre-Start Holding Open / Close times	Sama Abha Parks- Abha

17:30h	Pre-Rally press conference	Aseer HQ – Abha palace hotel
19:00h	Aseer Rally 2022 Ceremonial start	Sama Abha Parks- Abha
19:30h	Expected first car enter Service Park	Service Park – Abha palace hotel
Friday, September 23rd		
07:00h-20:00h	Rally office opens	Aseer HQ – Abha palace hotel
07:30h	Issuing of road book Leg 1 Section 1	Service Park – Abha palace hotel
08:00h-20:00h	Media center open	Aseer HQ – Abha palace hotel
08:00h	Start Leg 1 Section 1	Service Park Out
10:00h	Start SS 1A	Al Ghadah – Al Qaah
Approx. 14:40h	Finish Leg 1 (Estimated time for first car)	Abha Service IN
20:00h	Publication of the Start List for LEG 2	Sportity - Website
Saturday, September 24th		
07:00h-20:00h	Rally office opens	Aseer HQ – Abha palace hotel
07:00h-08:00h	Re-Scrutineering for vehicles to restart after retirement – Scrutineering venue	Service Park – Abha palace hotel
07:30h	Issuing of road book Leg 2 Section 2	Service Park – Abha palace hotel
08:00h-20:00h	Media center open	Aseer HQ – Abha palace hotel
08:00h	Start leg 2	Service Park Out
10:00h	Starts SS 2A	Tareeb - AlQaah
Approx. 14:25h	Finish of Leg 2 (estimated time of first car) (Finish Holding) Post rally scrutineering and final checks	Abha Parc Ferme / Finish Holding IN,
14:45h	Collection of the tracking devices – Finish Holding – Scrutineering Venue	Service Park – Abha palace hotel
17:00h	Provisional Classification	Sportity - Website
After the stewards have declared the classification final	Publication of Final Classification	Sportity - Website
17:30h	Post Rally Competitor press conference	Aseer HQ – Abha palace hotel
19:00h	Finish ceremony and prize giving	Sama Abha Parks- Abha
	Closure of the event	

## 4 ENTRIES

### 4.1 Opening and Closing Dates for Entries:

- Wednesday, August 31<sup>st</sup>, 2022 Entries Open
- Saturday, September 17<sup>th</sup>, 2022 @ 12:00h (local time) Entries Closed

### 4.2 Entry Procedure

Entries must be submitted in accordance with the 2022 FIA CCRSR Articles 16 & 18. See also FIA ISC Articles 3.8 & 3.14.

Entries must be made using the online form available on the website [www.saudi-championship.com/asir-rally](http://www.saudi-championship.com/asir-rally) & [www.samf.gov.sa](http://www.samf.gov.sa) and on Sportity App. If the application is sent by fax, by email or made electronically, the original duly signed entry form must reach the Organisers within 3 days following the close of entries. A copy of the valid competitor's licence must accompany the entry form. If one of the drivers will be the competitor, a copy of the valid competitor's licence and a driver's competition licence must accompany the entry form.

Mailing address for entry form:

Saudi Auto Automobile & Motorcycle Federation  
KSA 4627 Al Baji – Al Sharafiyah Dist. Unit # 2 Riyadh, 12724 - 7265  
Building #: 4627  
Tel.: +966 (11) 880 4614  
Fax: +966 (11) 880 4661  
Email: [info@samf.gov.sa](mailto:info@samf.gov.sa)  
Web: [www.saudi-championship.com/asir-rally](http://www.saudi-championship.com/asir-rally) & [www.samf.gov.sa](http://www.samf.gov.sa)

An entry application (including electronic) will be accepted only if accompanied by the total entry fees. The entry fee must be credited in full to the organiser's bank account, all bank charges must be paid by the sender:

Bank Name:	Saudi National bank
Account Name:	Saudi Arabian Motor federation
IBAN:	SA03 1000 0022 3611 8400 0100

Anyone wishing to take part in the Event must send the entry form, duly completed, to the secretariat of the event no later than the schedule mentioned in 4.1 above along with the entry fee, accompanied by at least:

- The entrant's full name as it appears on the competition licence (copy required)
- The full name of driver & co-driver, their nationality, and their addresses
- Competition license number and driving license number of each member of the crew (copy required)
- The characteristics of the vehicle, group, and class
- The FIA Technical Passport number (TT-XX-XXX)
- The FIA Homologation Form number *for T2 vehicles*
- ASN permission to take part in the event (copy required)
- Driver & Co-Driver passports or identification (copy required)

An entry application will be accepted only if accompanied by the total entry fees or by a receipt issued by the competitor's ASN. Entrants other than the first or second driver must hold an appropriate Entrants Licence issued by their ASN. A copy of the Entrant licence must accompany the entry form.

#### 4.3 Number of Entrants accepted and Vehicle Classes

4.3.1 The maximum number of entrants will be limited to "80".

4.3.2 If more than the maximum number of entries is received, the acceptance of entries among the non-priority drivers will be at the sole discretion of the Organiser.

4.3.3 The minimum number of entrants required is "25". If that number is not reached, the Organiser may cancel the competition after obtaining the Chairman approval.

#### 4.4 Accepted Groups / Classes

4.4.1 The Eligible cars, Groups / Classes of vehicles which will only score points on the 2022 Saudi TOYOTA Rally Championship (national classification) will be classified as per the bellow table.

Group / Class	National Category / Classification Vehicles
T1.U	Prototype Cross-Country Cars "Ultimate".
T1	T1 4x4 Petrol and Diesel
T2	Series Production Cross-Country Cars - Petrol and Diesel
T3	Lightweight Prototype Cross-Country Vehicles
T4	Lightweight Series Production Side-by-Side Cross-Country Vehicles
*T5	Cross-Country Trucks

\*Accepting Group T5 – Series Cross – Country Trucks (at the organizers' discretion)

4.4.1.1 The event is open to vehicles of a maximum gross weight of up to 3,500 kg for Groups T1 & T1-U four or two-wheel drive, T2, T3 and T4 in due possession of a registration certificate. Vehicles, complying with the 'Score' regulations, will be accepted in the competition as per Article 8 (CCRSR). These vehicles must comply with the safety specifications laid down by the International Convention on Road Traffic, as well as the safety specifications laid down by the FIA regulations and by these regulations. Group T5 - Series Cross-Country Trucks (Might be accepted at the organizers' discretion)

#### **IMPORTANT Notes:**

- Vehicles entered in a class with less than 5 entrants will be competing only for the general classification, group classification.
- Drivers don't have the right to request any change of the group or the class after publication of the Eligible start list for leg 2.
- Car numbering is upon the discretion of the organizers, Drivers have no right to protest or complain on the car number.

4.4.2 *For Reference only*: The Eligible cars and Groups/Classes of vehicles as per Article 8 of the 2022 FIA CCRSR

Group	Class	Vehicle
T1	T1.1	Prototype Cross-Country Cars 4x4 (complying with 2022 Appendix J, Art. 285)
		Prototype Cross-Country Cars 4x4 complying with 2009 Appendix J, Art. 285 (see Art. 8.4 of the 2022 CCRSR)
		Prototype Cross-Country Cars 4x4 with central or rear engine with a FIA Technical Passport drawn up before 31/12/2005 (see Art. 8.6.2 of the 2022 CCRSR)
		Series Production Cross-Country Cars with expired homologation, complying with 2022 Appendix J, Art. 284 (see Art. 8.6.1 of the 2022 CCRSR)
	T1.2	Prototype Cross-Country Cars 4x2 (complying with 2022 Appendix J, Art. 285)
		Prototype Cross-Country Cars 4x2 complying with 2009 Appendix J, Art. 285 (see Art. 8.4 of the 2022 CCRSR)
T1.3	Vehicles complying with "SCORE" regulations (see Art. 8.5 of the 2022 CCRSR)	
T2		Series Production Cross-Country Cars (complying with 2022 Appendix J, Art. 284) and Appendix IV to the 2022 FIA CCRSR
		Series Production Cross-Country Cars complying with 2021 ASO Dakar Auto regulations and Appendix IV to the 2022 FIA CCRSR
T3		Lightweight Prototype Cross-Country Vehicles (complying with 2022 Appendix J, Art. 286)
T4		Modified Production Cross-Country Side-by-Side (SSV) Vehicles (complying with 2022 Appendix J, Art. 286A)
		Modified Production Cross-Country Side-by-Side (SSV) Vehicles (complying with 2021 ASO Dakar Auto regulations)

All the Vehicles even if classified as per the above table art. 4.4.2, will be re classified according to the national classification mentioned in 4.4.1 above, for the final classification of the event and the 2022 Saudi TOYOTA Rally Championship.

Only T1, T3 & T4 cars are eligible to score points in the FIA World Cup for Cross-Country Bajas and FIA Middle East Cup for Cross-Country Bajas. If the event is sanctioned by the FIA

#### 4.5 Entry fees and packages

4.5.1 Any entry not accompanied by the entry fee, or by a receipt issued by the competitors' National Sporting Authority shall be, according to Art. 3.9.3 of FIA ISC, *null and void*.

#### 4.5.2 Entry Fees with the organiser's optional advertising (see FIA CCRSR Article 20).

Entries	Fees
With the Organisers' compulsory advertising and optional advertising:	
Entrant as the driver or co-driver	<b>SR 6000</b>
Entrant as a legal entity	<b>SR 6000</b>
Without the organiser's optional advertising:	increase of 60%
**GPS tracking pre – installation equipment: <b>(Non-refundable)</b>	<b>SR 200</b>
**Tracking & NAV deposit refundable after returning the device	<b>SR 2500</b>

**\*\*the payments of SR 200 and SR 2500 must be paid** with the entry fees or during admin checks in cash or Credit Card only, **an extra 10% non-refundable fees if paid by a credit cards**

#### 4.5.3 Entry Fees Package:

#	Included	T1	T2	T3	T4 (SSV)
1	Insurance (third party)	√	√	√	√
2	Rally car plates kit (numbers, obligatory & optional advertising, etc.)	1	1	1	1
3	Rally Documents Kit (Road Books)	1	1	1	1
4	Set of wrist bands for crew x2, team manager x1, team members x4, and service x3 (armband)	1	1	1	1
5	Team car plate (Service)	1	1	1	1
6	Team Manager car plate (minimum 2 race cars)	1	1	1	1
7	Merchandise (Driver & Co-Driver)	√	√	√	√
8	Service Area 15x10m	√	√	√	√

#### 4.6 Local support package

- There will be no Local Support Packages.

#### 4.7 International Support package

- There will be no international Support Packages.

#### 4.8 Payment Details

Payments by all competitors shall be paid before the 17<sup>th</sup> of September 2022, and shall be paid by cheque attached to the entry form or by bank transfer to the account indicated below, **all bank charges must be paid by the sender**. (In the latter case, adequate proof of payment must be attached to the entry form):

Bank Name: National Commercial bank  
Account Name: Saudi Arabian Motor federation  
IBAN: SA03 1000 0022 3611 8400 0100

#### 4.9 Entry fee refund

The entry fee shall be refunded in full:

- If the event does not take place
- To teams whose entry application is rejected
- The Organizers will reimburse 50% of the entry fees to those competitors who start the event.
- The Organizers may partially refund entry fees (up to a max 50% of the paid entry fees) to those entrants who, for reasons of force majeure, were unable to start the rally.

## 5 INSURANCE COVER

### 5.1 Third Party Insurance:

The Entry Fee includes the insurance premium, which guarantees the Competitors cover for civil liability towards third parties (Public Liability). The indemnity provided under this insurance is the equivalent of SR 50,000 as total minimum liability cover. This insurance will commence from the beginning of the Rally until the end of the Event or up to the moment of permanent retirement, disqualification or exclusion. The insurance covers for competitors running within the itinerary of the event only.

### 5.2 Insurance Company:

The Insurance will be covered by SAMF during the event.

### 5.3 Exclusion:

The insurance policy on no account covers the theft of vehicles, spare parts or any other properties. The service, auxiliary & truck vehicles, even those bearing special plates issued by the Organisers, are not covered by the insurance policy of the event; hence, their insurance policies remain the sole responsibility of the owner.

### 5.4 Organisers Liability:

The Organisers decline liability for any accident caused to competitors and competing cars during the whole of the event, and in case of cataclysm, riots, demonstrations, vandalism etc. Competitors and crewmembers will have to sustain all consequences (damages, fines and penalties) created by any accidents. Organisers also decline any liability for breach of the Saudi Laws and regulations.

### 5.5 Additional Insurance:

In addition to the insurance covered by the Organiser, all Competitors are required to provide their own insurance covering all cars used in Saudi to cover civil liability towards third parties for the entire duration of their visit in the case of foreign crews, or permanent cover in the case of Saudi residents. This is to cover competitors while they are on the road sections, or on public roads or highways.

### 5.6 Proof of Insurance:

All Competitors must be able to present the insurance papers at the Administrative Checks. The burden of proof for a valid insurance rests solely on the competitor.

### 5.7 In case of accident:

During the Rally itinerary, a competitor or his representative must notify in writing the Clerk of the Course, the Crew's Relations Officer or the Organiser with a maximum delay of 24 hours, in case an accident occurs, describing the circumstances of the accident as well as the names and addresses of the injured.

## 6 ADVERTISING & IDENTIFICATION

### 6.1 Obligatory Organiser's advertising

▪ Text of the obligatory advertising	Rally Aseer 2022
▪ Two competition number plates size (doors)	67x17cm
▪ One competition number plates size (roof)	50x52cm
▪ One rear competition number	42x21cm
▪ One front windscreen panel	20x10cm

The Organiser shall supply each crew with the identification number mentioned above, which must be affixed to their vehicles in the stated positions prior to scrutineering. T3 & T4 Vehicles are not allowed to cut the door panels (Size 67X17cm)

For more details refer to Article 19 of the 2022 FIA CCRSR V2 and appendix 3 of these regulations.

### 6.2 Optional Organiser's advertising

- The text will be announced to competitors in a Bulletin.
- Two panels, 50x52cm to be affixed on the right and left sides of the vehicle
- Two front windshield top left and right corners 25x10cm
- Spaces on the vehicle must be kept free, see Appendix 3 of these regulations for the location of the Optional Advertising (+60% if rejected).

### 6.3 Driver's & Co-Driver's Names & Identification

6.3.1 The first initial(s) and surname of the driver and the co-driver, followed by the national flags of the country of the ASN from which they have obtained their licences, must appear on both sides of the front wings or front doors of the vehicle. The letters must have a height of 30 to 50mm.

6.3.2 The members of the Crew will be identified by means of an identity wrist band (bracelet). The emergency number and name of the event will be written on the wrist band.

### 6.4 Restrictions on Advertising

Competitors are allowed to affix any kind of advertising to their cars, if:

- It is authorised by the National Laws and the FIA Regulations.
- It is not likely to give offence.
- It is not political or religious in nature.
- It respects the regulations on competition numbers.
- It does not interfere with the crew's vision through the windows.

### 6.5 National Restrictions on Advertising

- Tobacco: Advertising of tobacco, tobacco products and imitations, as well as smokers' requisites is forbidden according to the Saudi legislation on cars, competition\service equipment and on the Team members' outfits.
- Alcohol: Advertising of alcoholic beverages is strongly restricted by law and not allowed on competing cars, service cars, equipment, and clothes.



## 6.6 Breach of regulations

The crews must ensure that the advertising is properly affixed throughout the running of the event. If compulsory or optional advertising is absent or wrongly affixed, a fine of 10% of the entry fee will be incurred for a first offence, and 100% of the entry fee for each repeated offence.

## 7 TYRES

### 7.1 Regulations Regarding Tyres

- In accordance with Article 10 of the FIA CCRSR & Article 10 of Variation V2 of the FIA CCRSR.

### 7.2 Number of Tyres

- T1 FIA Priority drivers are allowed a maximum of 10 tyres for all the Rally.

## 8 FUEL

### 8.1 Technical Requirements & Compliance

- All types of fuel must follow Appendix J Art. 252.9. (Art. 57 of the FIA CCRSR).
- Refuel stations\locations are marked in the Road Book, competitors are obliged to refuel in these stations only.
- Fuel available in these stations is Diesel, Gasoline 91 and 95 Octane.
- For more details refer to Articles 55, and 56, and 57 of the 2022 FIA CCRSR.

## 9 ADMINISTRATIVE CHECKS

### 9.1 Documents to be presented

To minimize the time of the administrative checks, make sure to bring and present the following documents:

#	Document
1	Competitor's competition license
2	Driver & Co-Driver competition licenses
3	Driver & Co-Driver valid driving licenses
4	Driver & Co-Driver passports/identification
5	ASN authorization for all foreign Competitors and/or Driver's
6	Completion of all details on the Entry Form
7	Rally Car documents and Registration papers
8	Cars Complete Original FIA Technical Passport
9	Cars Complete Original FIA Homologation form (T2)
10	Rally Car Insurance cover certificate
11	Permission to use the vehicle (where the owner is not a crew member)
12	Driver & Co-Driver medical aptitude certificates

9.1.1 Additional Requirements: A refundable deposit of ***SR 2500 MUST*** be paid in cash or credit card during documentation for Tracking & Navigation equipment. ***An extra 10% non-refundable fees if paid by a credit card.***

## 9.2 Timetable

- The Administrative Checks will take place according to Article 3 Programme of these regulations. A schedule for each competitor will be published in a bulletin. The presence of at least one crew member or an authorised Team Member/Representative is compulsory.
- Any competitor or representative reporting outside their time schedule for administrative checks the competitor will be penalised €15/min to a maximum of 15 minutes, thereafter the competitor will be reported to the Stewards who may apply a penalty at their discretion.

## 9.3 Location:

Aseer HQ – Abha palace hotel as per the address in Article 2.8.

## 10 SCRUTINEERING, SEALING & MARKING

### 10.1 Venue & Timetable

10.1.1 Service Park – Aseer HQ – Abha palace hotel as per the address in Article 2.8.

- Scrutineering Timetable: A schedule for each competitor will be published in a bulletin.
- Any competitor or representative reporting outside their time schedule for scrutineering the competitor will be penalised €15/min to a maximum of 15 minutes, thereafter the competitor will be reported to the Stewards who may apply a penalty at their discretion.

10.1.2 When checking in at the scrutineering time control, competitors must comply with the following:

- All Rally plates, competition numbers and advertising plates must be already fitted
- Produce the driver's safety equipment for approval
- Produce NAV/GPS in working order, permanently fitted to the vehicle

### 10.2 Mandatory Documents

#	Document
1	Complete original FIA Homologation form for (T2) Vehicles only
2	FIA Technical Passport
3	SOS / OK board (A3 format)
4	Original Certificate form for the Roll-cage and Fuel tanks
5	Vehicle Registration Papers

The Complete original FIA homologation form / FIA Technical passport and all other necessary certifications / documents must be available for final checks also.

### 10.3 Mud Flaps

According to Art. 25.3.4 of the FIA CCRSR mud flaps must comply with Appendix J Article 283.19 and must always be in place and efficient.

#### 10.4 Driver's safety equipment

All items of clothing including helmets and FHR (Front Head Restraint) intended to be used, e.g., HANS devices, must be presented for scrutineering. They shall be checked for compliance with Appendix L, Chapter III.

The cars must be equipped with the medical kit according to FIA CCRSR Appendix III-1 and FIA Technical List n°83 and the survival kit according to FIA CCRSR Appendix III-2.

Because the selective sections are run in the desert and dunes the survival kit according to FIA CCRSR Appendix III-2.2 must also be carried on board.

Whenever a vehicle is in motion on any type of Selective Section and until the stop control, the crew must wear homologated crash helmets, all required safety clothing and equipment in compliance with Appendix L Chapter III – Drivers' Equipment of the ISC as intended by the equipment manufacturer and have their safety belts correctly fastened. Any infringement will be penalised by the Stewards.

#### 10.5 Necessary Technical Installations

##### 10.5.1 Safety Tracking System (FIA CCRSR Article 12.1)

All vehicles must only be fitted with the Safety Tracking System(s) provided by the Organiser. The instruction for the use of the Tracking System is in Appendix 5 of these SR.

Tracking devices shall be collected during the Administrative Checks as per Article 3 Programme. Tracking Officer will collect the devices from the vehicles at the finish Parc Fermé or Service Park for retired competitors.

##### 10.5.2 Navigation System (FIA CCRSR Article 12.2)

Competitors are obliged to be equipped with one or two Navigation System(s) (NAV-GPS) downloaded with the waypoints given by the Organiser. When a crew uses two NAV-GPS, it must indicate in writing, at scrutineering, which of the two will be considered as the official one

##### 10.5.3 Connection of the systems (FIA CCRSR Article 12.3)

The specifications for the standard power connector are laid down in the FIA CCRSR Appendix VI.

It is the competitor's responsibility to ensure that the Safety Tracking System and the NAV-GPS always remain permanently connected and switched on with the antenna connected throughout the duration of the competition any infringement will be penalised.

##### 10.5.4 GPS Data Logger (FIA CCRSR Article 13.1)

Any vehicle selected by the Organizer after the publication of the entry list may be equipped with a GPS Data Logger to monitor their performances during the event.

##### 10.5.5 Accident Data Recorder (ADR) (FIA CCRSR Article 13.2)

An Accident Data Recorder (ADR) complying with FIA Standard 8872-2018 "Accident Data Recorder" (listed in Technical List no. 88) *might* be installed in T1 cars manufactured from 2016 who is participating in this event. If the car is selected The ADR must be installed in accordance with the FIA ADR Installation Specification and manufacturer user's manual. Competitors failing to comply with this requirement will be reported to the Stewards.

#### 10.5.6 Organizer On-Board Surveillance Camera (FIA CCRSR Article 13.3)

Vehicles selected by the Organizer may be equipped with an OBSC to monitor all activities inside the vehicle during the event. Refusal to comply will be reported to the Stewards who may impose a penalty of (the competitor will not be allowed to start or will be disqualified immediately).

#### 10.6 On Board Cameras

Competitors wishing to use a camera must supply the following information to the organiser at least one week before the start: Competitor's name, car number, competitor's address and use of footage.

The FIA officials may recover the footage at any time. The footage may be used by the FIA officials.

All authorised cameras will be identified by an adhesive decal and must be mounted in the vehicle at the time of scrutineering.

For further information please refer to Article 11 of the FIA CCRSR.

#### 10.7 Electronic Equipment

Any radio or electronic means of communication, or any other device not expressly permitted in FIA CCRSR regulations is forbidden on board the vehicles.

It is optional for the competitors to use a GPS-based Trip Meter. No functions other than measuring (kilometres, times, speeds, course) may be integrated into the GPS Trip Meter.

#### 10.8 Windscreen:

In case the windscreen is absent due to an accident, at the start of a Leg, the wearing of a full-face helmet with a visor or goggles of motocross type, or an open face helmet with motocross type of goggles is compulsory for all members of the crew, otherwise the vehicle will not be permitted to start the Leg.

## 11 OTHER PROCEDURES

#### 11.1 Official time used during the event

The official time will be according to the GPS (KSA time = GMT +3)

#### 11.2 Drivers Briefing

- The drivers' briefing will take place in Aseer HQ – Abha palace hotel as per Article 3 Programme, we will provide further information about selective sections and answer any questions the crews may have.
- The presence of at least one crew member is compulsory, a penalty of €150 will be imposed for not attending the briefing.

#### 11.3 Pre Start Area

- Pre Start Holding Area will be setup on-site, competitors MUST enter the Holding Area as per Article 3 of these regulations.
- The holding area will be secured. Access is limited to Crew members and Media representatives carrying the appropriate identification\accreditation.
- Cars must be driven by one of the drivers or any team member representative to the Pre Start Holding area where refuelling is strictly forbidden at Pre Start Holding area, any kind of other service will be reported to the Stewards and the team involved will acquire a penalty.

- Entering the pre start holding area outside the indicated time window according to Article 3.3 of these regulations up to a maximum 30 minutes, will incur a cash penalty of €150., any lateness over than 30 minutes the team involved will be reported to the Stewards who may apply penalties at their discretion.

#### 11.4 Rally Aseer Ceremonial Start Procedure & Order

- The Ceremonial Start will take place in Sama Abha Parks- Abha according to Article 3 Programme of these regulations. It is mandatory for both Crew members to attend.
- The Ceremonial start will be in ascending car number order, starting from the First competitor to the Last.
- Cars will start at one (1) minute interval. Then they will return to the Service Parc
- No Timecards will be given, competitors will follow marshal's instructions.
- It is mandatory for all crew members to wear their racing overalls, boots during the Ceremonial Start ramp. Crews not complying with this will be reported to the Stewards.

#### 11.5 Electronic Start Procedure at Selective Sections

See Appendix 7 of these regulations for the Start Light procedure in the Selective Sections. Chronomoto system with their beams and timing equipment will be used during Rally Aseer 2022.

#### 11.6 Start of the Rally

##### 11.6.1 Publication list of competitors eligible to start and start list

- The starting list for LEG 1 established according to Article 32.1 of the 2022 FIA CCRSR will be published on the Digital Notice Board (see the Programme in Article 3 of these regulations).
- The starting list for LEG 2, established according to Article 32.2 of the 2022 FIA CCRSR will be published on the Digital Notice Board (see the Programme in Article 3 of these regulations).

##### 11.6.2 Official start of competition: the official competition start of the Rally will take place from TC 0 Service Out.

#### 11.7 Running of the Rally

- Attention: whilst the route generally avoids being in proximity of farms and inhabited areas, competitors are advised when driving in the vicinity their speed should be restricted. Crews must always take every precaution to minimize the nuisance and disturbance to all forms of livestock.
- Road Section and Selective Sections: The itinerary of the Rally is made up of Road Sections with a scheduled time and roads open to traffic.
- It is not allowed for any competitor to have his vehicle carried on a trailer on road sections as it is part of the competition and any violation of that will be reported to the Stewards.
- The Selective Sections on leg 1 & Leg 2 will be run in two parts separated by a Transfer Zone according to Art. 2.41 Of the 2022 FIA CCRSR. For service in the transfer zone refer to Article 11.18.1 of these regulations.
- All competitors must take into consideration that while driving on Transfer Zone all Traffic laws that will apply, and any traffic laws Infringement including Speeding will be reported to the stewards who might go up to disqualification. (While on Transfer Zone the exact speed will be monitored by Anube Sport / Stella devices) and penalty will apply
- For safety reasons a system of Red Flags deployed by marshals will be positioned to signal competitors to stop or slow down, all competitors must abide by this procedure.

#### 11.7.1 Start Intervals

- Start intervals of at least 3 minutes shall be given to at least the first ten vehicles on the starting list, as determined by the procedures.

#### 11.7.2 Speed Control Zone Penalties

SPEED	TIME PENALTY	FINE
Between & Including 1 & 5 KM/H	10 Sec x # of Pulses	
Between & Including 5 & 15 KM/H	1 Minute x # of Pulses	€50
Between & Including 16 & 40 KM/H	2 Minutes x # of Pulses	€100
More than 40 KM/H, 1 <sup>st</sup> Pulse	5 Minutes	€300
More than 40 KM/H, 2 <sup>nd</sup> Pulse	10 Minutes	€500
More than 40 KM/H, 3 <sup>rd</sup> Pulse	15 Minutes	€700
More than 40 KM/H, 4 <sup>th</sup> Pulse	Stewards decision	Stewards decision

- Please refer to Article 37 of the FIA CCRSR.
- The exact speed will be monitored by: Anube Sport / Stella

#### 11.7.3 Retirement:

- Any crew which has failed to complete a leg will be assumed to re-start the event from the start of the next leg unless they confirm otherwise to the Clerk of the Course in writing.
- A crew wishing to retire completely must notify the Clerk of the Course in writing. This shall apply to any vehicle which has not been classified on the grounds of exceeding the time limit or has failed to report to a control but shall not apply where the vehicle has been disqualified for breach of eligibility requirements, traffic infringements or by a decision of the Stewards.
- Drivers who retired before the end of the Rally must notify the Clerk of the Course of their retirement maximum one (1) hour prior to the publication of the start list of next LEG and must hand in their time card at the closest Control post. Competitors failing to abide to this prescription will be fined €150.

#### 11.7.4 Maximum Permitted Lateness at a TC

- Any lateness exceeding 30 minutes of any individual target time or an accumulative lateness exceeding 30 minutes at the end of each section or of a leg, will result in the competitor concerned being considered to have retired at that control, and the competitor will receive a Time Control (TC) penalty for each missed TC and, eventually, a Section Penalty for each Selective Section not started or not completed.

#### 11.7.5 Section Penalties

- Section Penalties will be applied in Rally Aseer 2022 in accordance with Articles 49 Appendix V2 of the 2022 FIA CCRSR.

#### 11.7.6 Waypoint Penalty

- Each missed waypoint will be penalised in accordance with Article 43.1.6 of the 2022 FIA CCRSR.
- The total number of waypoints which may be missed during a Leg is 40% of the total number of waypoints of the Leg concerned. If a crew has less than the required number of waypoints it is deemed to have retired from the Leg and will be given the section Penalty for the Leg concerned.

#### 11.7.7 Maximum Time allowed in the Selective Sections

- The Maximum Time allowed in the Selective Sections are:

Selective Section	Length – Km	Max. Time Allowed – hh:mm
SS1 A "Al Ghadah" SS1 B "Al Qaah"	95.35 + 28.81 (TZ) + 59.67	02:30 + 00:50 + 01:50
SS2 A "Tareeb" & SS2 B "Al Qaah"	95.34 + 33.35 (TZ) + 59.67	02:30 + 00:50 + 01:50

The maximum time allowed above may be modified at any moment by the Stewards, upon the proposal of the Clerk of the Course. Crews will be informed thereof as soon as possible. Any Competitor who misses to pass through (DT) the way point used to define the beginning of a transfer Zone within a selective section, cannot complete the second part of the selective section.

#### 11.8 Finish procedure

- After parking their vehicles in the Parc Fermé upon passing the finish line, participants team (crew) must remain available by phone (mobile) until the final classification have been posted.
- Holding Area will be setup on-site, competitors MUST enter the Finish Holding Area and follow marshal's instructions.
- The holding area will be secured. Access is limited to Crew members and Media representatives carrying the appropriate identification \ accreditation.
- The Podium & Prize Giving will take place according to Article 3 Programme of these regulations. It is mandatory for both Crew members to attend.
- The prize giving/trophies will be given in descending order according to classification.

#### 11.9 Classification

##### 11.9.1 Classifications during the Rally will be as Follows:

- Unofficial Classifications of the Selective Sections
- Unofficial Partial Classification of LEG 1
- Unofficial Partial Classification of LEG 2
- Final Classifications

11.9.2 The final classification will **NOT** be distributed after the event. It will be published on the Digital Notice Board – Sportity and on the website [www.saudi-championship.com/asir-rally](http://www.saudi-championship.com/asir-rally) & [www.samf.gov.sa](http://www.samf.gov.sa)

##### 11.9.3 In order to be classified:

The crew must take part of the Ceremonial Start and the super special stage (if any).

#### 11.10 Safety, Navigation & Tracking Equipment

See Appendix 5 of these regulations

#### 11.11 "Vehicle to Vehicle Alarm System" Article 48.3 of the FIA 2022 (CCRSR)

See Appendix 5 of these regulations

11.12 Assistance in Case of Accident: Article 48.4 of the FIA 2022 (CCRSR)

See Appendix 5 of these regulations

11.13 Qualifying Stage

Not Applicable

11.14 Shakedown

Not applicable.

11.15 Super Special Stage regulations & order

Not applicable.

11.16 Permitted Early Check in

Early check in is permitted in the following Tc's

- TC1A Technical Zone IN
- TC 2A Parc Ferme / Finish Holding IN

11.17 Road Book Delivery

Road Book will be delivered 30 Minutes before the Start time of each car at Leg 1 and Leg 2

11.17.1 Ceremonial start all cars Wednesday, September 21<sup>st</sup>, 2022 @ Admin check

11.17.2 LEG 1 Section 1 Friday, September 23<sup>rd</sup>, 2022 First car @ 07:30 Service Parc

11.17.3 LEG 2 Section 2 Saturday, September 24<sup>th</sup>, 2022 First car @ 07:30 Service Parc

11.18 Servicing of Vehicles

11.18.1 General Service Regulations

- There will be one Service Park for the duration of the Rally.
- The Service Park is located in Aseer HQ – Abha palace hotel as per Article 2.8 of these regulations.
- Maximum speed inside the Service Parc is 25 km/h
- In the service area, only three team personnel may work on a competing vehicle. They will be identified by a distinctive armband supplied by the organizer  
The crew may work freely during this period
- Servicing the vehicle in the Transfer Zone is allowed only by the Crew using solely the equipment on board and with no external physical assistance except by crews with group's vehicles whom are still in the competition for the current leg may assist each other.
- Servicing the vehicle by the Service Team is restricted to be done only inside the Service Park, except for retired vehicles intending to re-start may be repaired outside of the Service Park. Obtaining a permission from the CoC is a MUST if the repair will take place inside a selective section.
- Servicing in a closed and/or private place is not authorised. If a car is serviced inside a closed tent, the Clerk of the Course must be informed and any official of the event must be allowed to enter the tent at any time.
- All the infractions of the Service and Refuelling rules reported by the Judges of Fact or by other Officials will involve a penalty that will be decided by the Stewards of the Meeting and that can go as far as the disqualification from the race.
- For more details refer to Article 50 of the 2022 FIA CCRSR.



#### 11.18.2 Access Times for Service vehicles

- The service park will open for logistics operations only as per Article 3 Programme, the service vehicles will be allowed to enter the service park on that date only to off-load and setup their service area.
- The service park will be fully operational as per Articles 2.8.3 & 3 of these regulations.

#### 11.18.3 Service Space

- Service space is included in the entry fee, space allocated for each entrant is 150sqm (15x10m). If the entrant requires more space, he / she can purchase extra space in 50sqm (5x10) increments at **SR 500** / 50sqm (5x10m).
- If two or more competitors share the same service area or if the competitor wish to add extra space, the organiser must be informed of this request as per Article 3 of these Regulations.

#### 11.18.4 Environmental Mat

Inside the service park and the Parc Fermé, competitors are obliged to lay a groundsheet (a minimum of 1 metre longer and wider than the vehicle in running order), under their cars to avoid the discharge of liquids on the soil (FIA CCRSR 51.2.2). Otherwise, the Clerk of the Course will award a penalty of **€150** against the car's team, and it will be reported to the Stewards.

#### 11.18.5 Garbage Bins

Inside the service park, the organiser will place garbage bins. Competitors must ensure their service location is clean before, during and after the rally, the Clerk of the Course will award a penalty of **€150** to the competitor who has registered the car.

#### 11.18.6 Service plates

One "Service" plate will be provided to each competitor for free, which can be used for any vehicle, including a truck. Extra plates are available with the following fees:

Item	Price SR
"TRUCK" Plate	<b>SR 5,000</b>
"SERVICE" Plate	<b>SR 1,500</b>
"AUXILIARY" Plate	<b>SR 250</b>

- "TRUCK" Plate:
  - Vehicles over 3500kg
  - These vehicles can enter the service park ONLY on Wednesday, September 21<sup>st</sup>, 2022 as per Article 3 Programme and must be parked there until the end of the event.
- "SERVICE" Plate:
  - Vehicles less than 3,500 kg (van) used as service assistance.
  - These vehicles can enter in the service park every day of the event.

- "AUXILIARY" Plate:
  - Vehicles less than 3,500 kg for the transfer of the team staff.
  - These vehicles can enter in the service park every day of the event.
- All these vehicles must affix their plate on the top centre of the front windshield.

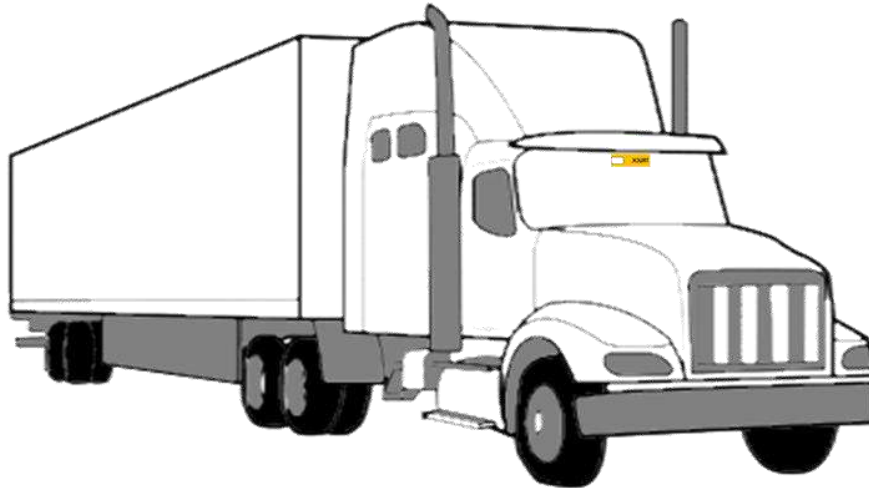
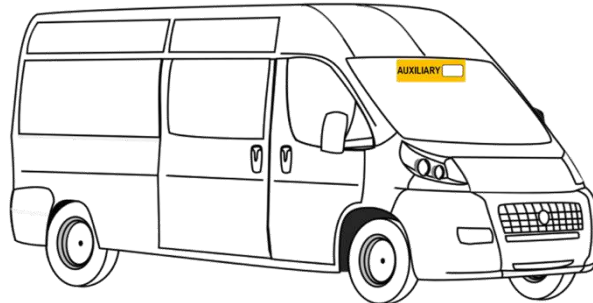
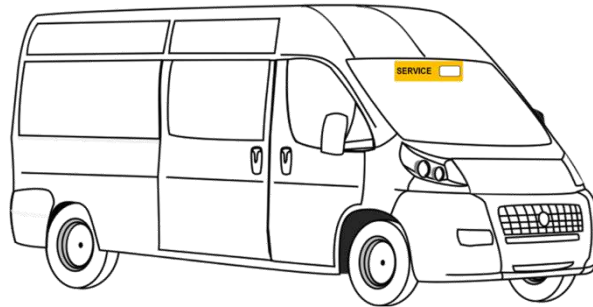

11.18.6.1 The "SERVICE" / "AUXILIARY" / "TRUCK" Plates must be affixed to the authorized vehicles. During the Rally, no vehicle will be permitted to enter the Service Park unless these plates are affixed. Inside the Service Park the staff in charge for servicing the competitor's vehicle must wear their armband supplied by the Organizers during administrative checks in a very visible way.

## 11.18.7 Fuel & Refuelling

### 11.18.7.1 Fuel/Refuel

- In the Service Park it is forbidden to refuel.
- Refuelling is permitted only in the designated commercial fuel stations, or in the designated refuel zones. Solely for the purpose of assisting with the refuelling procedure of their vehicle, two team members of each crew may access the Refuelling Zone (other than inside a competitive part of a Selective Section), a third being present with a fire extinguisher. In commercial fuel stations a team member may proceed with the payment but will have to stay away from the vehicle.
- To access a refuelling zone, it is recommended that the team members wear goggles and homologated clothing, and it is mandatory to wear long clothes.
- Engines must be switched off throughout the refuelling operation and the crew must remain outside the vehicle during refuelling, and it's forbidden to use mobile phones and radio communications while in the RZ.
- The fuel stations authorized will be indicated in the competitor Road Book with "FUEL STATION".

### 11.18.7.2 Commercial filling Petrol station along the road section and transfer zone

- The designated Fuel Stations along the Road section are:

Section	Road Section	Road Book	Type of Fuel
1	TC 0 to TC 1	4.50 KM	95 / 91 / Diesel
1	TC 0 to TC 1	120.80 KM	95 / 91 / Diesel
1 Transfer Zone	DSS 1A to DSS 1B	118.13 KM	95 / 91 / Diesel
2	TC 1C to TC 2	4.50 KM	95 / 91 / Diesel
2	TC 1C to TC 2	107.28 KM	95 / 91 / Diesel
2 Transfer Zone	DSS 2A to DSS 2B	122.64 KM	95 / 91 / Diesel

11.18.8 All the infringements of the Service and Refuelling rules will be reported to the Stewards.

## 12 IDENTIFICATION OF THE OFFICIALS & MARSHALS

SS Commander	Red tabard with white Stripe & text " Stage Commander"
SS Post Chief	Blue tabard with white Stripes & text "Post Chief"
SS Safety Officer	Orange tabard with White stripes & text "Safety Officer"
SS Radio Point	Yellow tabard with blue radio symbol
Safety Marshals	Orange with black text "Safety Marshal"
CRO	Red jacket or tabard with Text "CRO"
Scrutineers	Black t-shirt or tabard with White Stripes & text "Scrutineer"
Medical	White tabard with red crescent on the back & text "Medical"
Media	Green tabard numbered with white Stripes & text "Media"
Marshal	Yellow Tabard numbered
Time Keeper	Orange tabard with White stripes & text "Timekeeping"

## 13 PRIZES

### 13.1 Podium / Prize Giving

- Date: Saturday, 24<sup>th</sup> September, 2022
- Time: 19:00
- Sama Abha Parks- Abha

### 13.2 Prizes

Prizes will be awarded according to the following list:

#### 13.2.1 General Classification

1 <sup>st</sup> Overall	2 Trophies
2 <sup>nd</sup> Overall	2 Trophies
3 <sup>rd</sup> Overall	2 Trophies

#### 13.2.2 Group Classification

##### T1U Classification

1 <sup>st</sup> T1.U	2 Trophies
2 <sup>nd</sup> T1.U	2 Trophies
3 <sup>rd</sup> T1.U	2 Trophies

##### T1 Classification

1 <sup>st</sup> T1	2 Trophies
2 <sup>nd</sup> T1	2 Trophies
3 <sup>rd</sup> T1	2 Trophies

##### T2 Classification

1 <sup>st</sup> T2	2 Trophies
2 <sup>nd</sup> T2	2 Trophies
3 <sup>rd</sup> T2	2 Trophies

##### T3 Classification

1 <sup>st</sup> T3	2 Trophies
2 <sup>nd</sup> T3	2 Trophies
3 <sup>rd</sup> T3	2 Trophies

##### T4 Classification

1 <sup>st</sup> T4	2 Trophies
2 <sup>nd</sup> T4	2 Trophies
3 <sup>rd</sup> T4	2 Trophies

#### 13.2.3 Best Ladies Crew (Both crew members must be female)

1<sup>st</sup> Overall 2 Trophies

#### 13.2.4 Finisher 2 Trophies

## 14 FINAL CHECKS, PROTESTS & APPEALS & FINES

### 14.1 Final Checks

- 14.1.1 The Final Checks will take place, according to Article 3 Programme in Scrutineering venue – Aseer HQ – Abha palace hotel, Service Park.
- 14.1.2 Competitors who are selected for final checks (Stewards' decision) must provide at least two mechanics and the proper equipment/tools (including all sealed spare parts) at the final Scrutineering venue.
- 14.1.3 Each selected car will be driven to and from the final Scrutineering by a designated member of the team (who must be present at the finish ceremony) and accompanied by an official.
- 14.1.4 In case of a protest, the protested car will be checked at the discretion of the Stewards.
- 14.1.5 Any teams required to undergo final checks must immediately follow the instruction of the marshals in charge, even if this prevents them from proceeding to one or more TC's.
- 14.1.6 The complete original FIA homologation form, the FIA Passport and other necessary certifications must be available for final checks.

### 14.2 Protest Deposit

- 14.2.1 The Protest deposit is: **SR 5000** If a protest requires the dismantling and re-assembly of a clearly defined part of the car, any additional deposit will be specified by the Stewards upon the proposal of the Technical Delegate or Chief Scrutineer (FIA ISC Art. 13.4.3).
- 14.2.2 The expenses incurred by the work and by the transport of the car shall be borne by the claimant if the protest is unfounded, or by the competitor against whom the protest is lodged if it is upheld.
- 14.2.3 If the protest is unfounded, and if the expenses incurred by the protest (Scrutineering, transport, etc.) are higher than the amount of the deposit, the difference shall be borne by the claimant. Conversely, if the expenses are less, the difference shall be returned to them.

### 14.3 Appeal Deposit

- 14.3.1 The National Appeal Deposit is fixed at **SR 15000**
- 14.3.2 The appeal deposit for an international appeal is published on the FIA website: <https://www.fia.com/international-court-appeal>
- 14.3.3 All protests and/or appeals must be lodged in accordance with Articles 13 and 15 of the FIA ISC and, where applicable, with the FIA Judicial and Disciplinary Rules.

### 14.4 Payment of Fines / Protest Deposit

- 14.4.1 Payment of fines: In Accordance with the organizer rules all fine payments must be paid in cash /credit card or bank transfer to the following address:

Bank Name:	Saudi National bank
Account Name:	Saudi Arabian Motor federation
IBAN:	SA03 1000 0022 3611 8400 0100

And must be paid within 12 hours of the Fine decision. An Extra charge of 10% if paid by a credit card.

## 15 APPENDIX 1 – ITINERARY

ASEER RALLY 2022							
LEG 1 Friday, September 23th, 2022							
TC SS	Location	SS km	Liaison km	Total km	Max. Time	Target Time	1 <sup>st</sup> Car Due
0	ABHA Service OUT - Start LEG 1						08:00
1	Start S.S. Al Ghadah		127.16	127.16		01:55	09:55
<b>DSS 1A</b>	<b>SS1A Al Ghadah الغضاة</b>	<b>95.35</b>	<b>0.10</b>	<b>127.26</b>	<b>02:30</b>	<b>00:05</b>	<b>10:00</b>
<b>ASS 1A</b>	<b>Finish SS1A Al Ghadah الغضاة</b>			<b>222.61</b>	<i>Expected time of arrival</i>		<b>(11:25)</b>
	Transfer Zone ( 50 minutes ) Petrol Station available					00:50	
<b>DSS 1B</b>	<b>SS1B Al Qa' Ah 1 القاعة 1</b>	<b>59.67</b>	<b>28.81</b>	<b>251.42</b>	<b>01:50</b>		<b>(12:15)</b>
<b>ASS 1B</b>	<b>Finish SS1B Al Qa' Ah 1 القاعة 1</b>			<b>311.09</b>	<i>Expected time of arrival</i>		<b>(13:10)</b>
	Stop S.S. Al Qa' Ah 1			311.09			
1A	Technical Zone IN *		73.65			01:15	14:25
1B	Technical Zone OUT / ABHA Service IN			384.74		00:15	14:40
	<b>ABHA Service A</b>						
	<b>LEG 1 TOTAL</b>	<b>155.02</b>	<b>229.72</b>	<b>384.74</b>			
		<b>40.29%</b>	<b>59.71%</b>	<b>100.00%</b>			
* Early Arrival Permitted					Sunrise	05:58	Sunset 18:06
LEG 2 Saturday, September 24th, 2022							
TC SS	Location	SS km	Liaison km	Total km	Max. Time	Target Time	1 <sup>st</sup> Car Due
1C	ABHA Service OUT - Start LEG 2						08:00
2	Start S.S. Tareeb		122.25	122.25		01:55	09:55
<b>DSS 2A</b>	<b>SS2A Tareeb تطيب</b>	<b>95.34</b>	<b>0.10</b>	<b>122.35</b>	<b>02:30</b>	<b>00:05</b>	<b>10:00</b>
<b>ASS 2A</b>	<b>Finish SS2A Tareeb تطيب</b>			<b>217.69</b>	<i>Expected time of arrival</i>		<b>(11:25)</b>
	Transfer Zone ( 50 minutes ) Petrol Station available					00:50	
<b>DSS 2B</b>	<b>SS2B Al Qa' Ah 2 القاعة 2</b>	<b>59.67</b>	<b>33.35</b>	<b>251.04</b>	<b>01:50</b>		<b>(12:15)</b>
<b>ASS 2B</b>	<b>Finish SS2B Al Qa' Ah 2 القاعة 2</b>			<b>310.71</b>	<i>Expected time of arrival</i>		<b>(13:10)</b>
	Stop S.S. Al Qa' Ah 2			310.71			
2A	ABHA Parc Ferme / Finish Holding IN *		73.65	384.36		01:15	14:25
	Prize Giving Ceremony **						<b>19:00</b>
	<b>LEG 2 TOTAL</b>	<b>155.01</b>	<b>229.35</b>	<b>384.36</b>			
		<b>40.33%</b>	<b>59.67%</b>	<b>100.00%</b>			
* Early Arrival Permitted					Sunrise	05:58	Sunset 18:05
** Follow Marshal's Instructions							
V.1.6							
	<b>Rally Totals</b>	<b>SS</b>	<b>Liaison</b>	<b>LEG Total</b>	<b>%</b>		
	LEG 1	155.02	229.72	384.74	40.29%		
	LEG 2	155.01	229.35	384.36	40.33%		
	<b>Total</b>	<b>310.03</b>	<b>459.07</b>	<b>769.10</b>	<b>40.31%</b>		

## 16 APPENDIX 2 – COMPETITORS' RELATIONS OFFICERS

### 16.1 Competitors' Relations Officers



Samer Hijazi

[hejazi\\_samer@hotmail.com](mailto:hejazi_samer@hotmail.com)

+966 55 666 6548

Arabic & English

### 16.2 CRO's Schedule

Wednesday, September 21 <sup>st</sup> , 2022		
08:00 – 14:00	Rally Office Administrative Checks	Aseer HQ – Abha palace hotel
15:00 – 19:00	Scrutineering	Service Park – Abha palace hotel
20:30	Driver's Briefing	Aseer HQ – Abha palace hotel
Thursday, September 22 <sup>nd</sup> , 2022		
09:00 – 13:00	Rally Office	Aseer HQ – Abha palace hotel
14:00 – 15:00	Re-Scrutineering/Re-Starting Vehicles	Service Park – Abha palace hotel
16:30	Publication of List of Eligible Starters Leg 1	Aseer HQ – Abha palace hotel
17:00 – 19:00	Ceremonial Start	Ceremonial Start Area
Friday, September 23 <sup>rd</sup> , 2022		
07:30	Issue of Road Book Leg 1	Service Park – Abha palace hotel
08:00	Start of Leg 1 (TC 0)	Service Park – Abha palace hotel
Approx. 15:45	Finish Leg 1	Service Park – Abha palace hotel
20:00	Publication of the start list of Leg 2	Aseer HQ – Abha palace hotel
Saturday, February 24 <sup>th</sup> , 2022		
07:00	Re-Scrutineering/Re-Starting Vehicles	Service Park – Abha palace hotel
07:30	Issue of Road Book Leg 2	Service Park – Abha palace hotel
08:00	Start of Leg 2	Service Park – Abha palace hotel
Approx. 14:40	Finish Leg 2	Service Park – Abha palace hotel
15:00	Parc Ferme & Final Scrutineering	Service Park – Abha palace hotel
17:00	Publication of Provisional Classification	Rally HQ
After Stewards Meeting	Publication of Final Classification	Rally HQ
19:00	Podium / Prize Giving	Podium/Prize Giving Area



## 17 APPENDIX 3 – DECALS & POSITIONS OF SUPPLEMENTARY ADVERTISING

### 17.1 Competition numbers

Baja plates and advertising will be provided by the Organiser and must be affixed as specified in the diagram below prior to Scrutineering

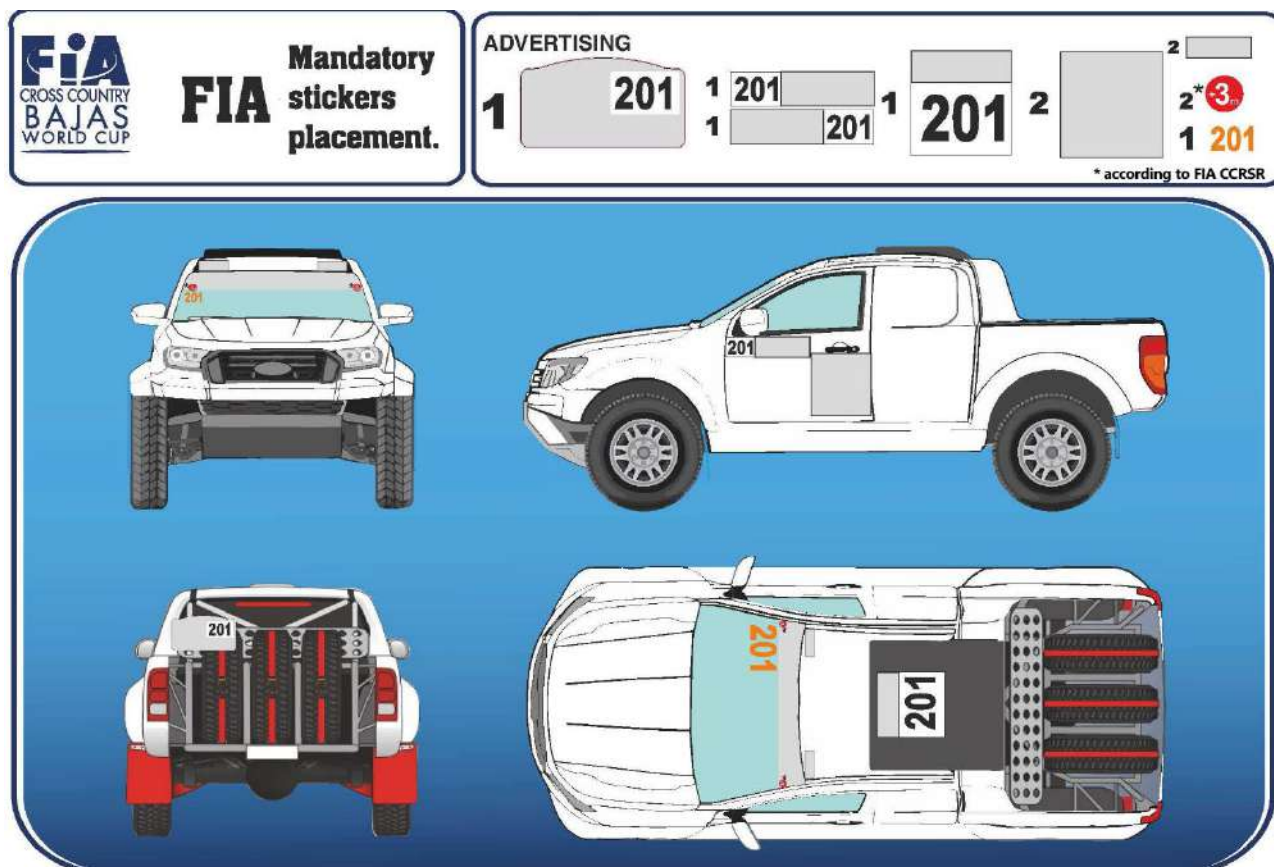

### 17.2 Event Plates

Decal #	Description
1	Two front door race number panels 67x17cm and one rear window race number 42x21cm, and one roof race number panel 50x52cm all these panels with compulsory advertising, and one front windscreen panel 20x10cm with the competition number.
2	Two panels, 50x52cm to be affixed on the right and left sides of the vehicle, on the area situated between the wheel arches if they are totally visible from the side, and two front windshield top left and right corners 25x10cm optional advertising (+60% if rejected).
3	The first initial(s) and surname of the driver and the co-driver, followed by the national flags of the country of the ASN from which they have obtained their licences, must appear on both sides of the front wings or front doors of the vehicle. The letters must have a height of 30 to 50mm.

## 18 APPENDIX 4 – FIA ISC APPENDIX L EXTRACTS

All competitors are reminded of Appendix L of the FIA ISC, in particular its Chapter III - Drivers' Equipment.

- Helmets (Appendix L, Chapter III, Art. 1)
  - All crews must wear crash helmets homologated to one of the FIA standards listed in Appendix L.
- Frontal Head Restraint (FHR, Appendix L, Chapter III, Art. 3)
  - All crews must use FIA approved FHR systems homologated to FIA standard 8858.
  - Approved FHRs, anchorages and tethers are listed in Technical List N° 29.
  - See also helmet compatibility chart in Appendix L, Chapter III, Art. 3.3.
- Flame-resistant clothing (Appendix L, Chapter III, Art. 2)

All drivers and co-drivers must wear overalls as well as gloves (optional for co-drivers), long underwear, a balaclava, socks, and shoes homologated to the FIA 8856-2000 standard (Technical List N°27) or 8856-2018 (Technical List N° 74).

*FIA Priority Drivers and Their Co-Drivers must wear as well as gloves (optional for co-driver), long underwear, a Balaclava, Socks, and Shoes, only homologated to the FIA 8856-2018 standard (technical list no. 74)*

Please pay special attention to the prescriptions of Art. 2 concerning embroidery and printing on flame-resistant clothing (manufacturer certificates etc.) as well as concerning the correct wearing of the clothing elements! See also FIA Cross-Country Rally Sporting Regulations Article 48.1.

- Biometric Devices (Appendix L, Chapter III, Art. 2.1)

Drivers may wear a device to collect biometric data during racing.

- If the biometric device is integrated into a protective garment homologated to FIA Standard 8856, the garment shall be homologated to FIA Standards 8856 and 8868-2018.
- If the biometric device is a stand-alone device, then the device must be homologated to FIA Standard 8868-2018 only. This device must be worn in addition to the garment homologated to FIA Standard 8856.

- Wearing of jewellery (Appendix L, Chapter III, Art. 5)

The wearing of jewellery in the form of body piercing or metal neck chains is prohibited during the competition and may therefore be checked before the start.

- MEDICAL AND SURVIVAL KIT (Appendix III of the FIA CCRSR)

A sealed and valid medical kit in accordance with the Specification for Cross Country Rallies and Bajas (Technical List n°83) must be placed inside the cockpit. The minimum weight must comply with Technical List n°83.

- Related Links:

FIA ISC and appendices: <https://www.fia.com/regulation/category/123>

FIA Technical Lists: <https://www.fia.com/regulation/category/761>

19 APPENDIX 5 – INSTRUCTIONS FOR USING TRACKING/NAVIGATION DEVICE

WAYPOINT PROXIMITY

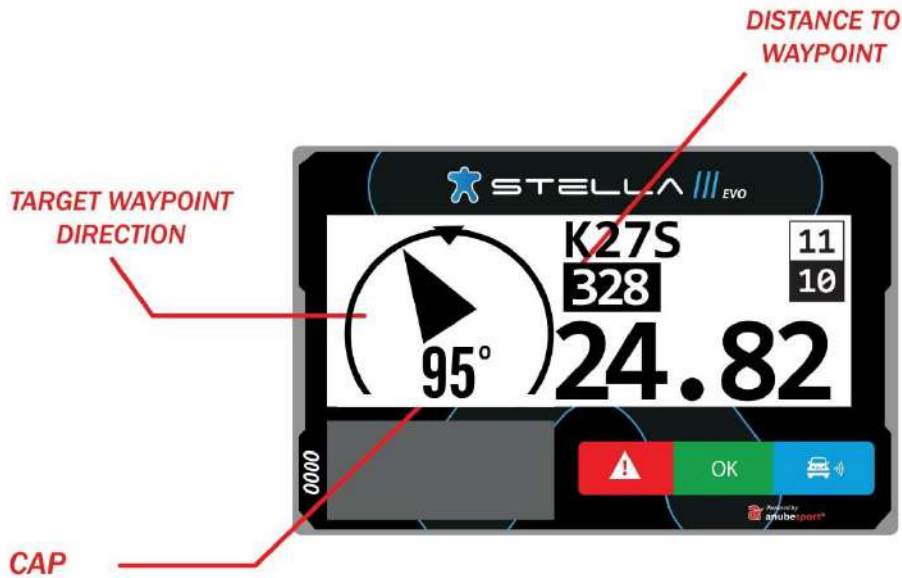

MAIN SCREEN



## SPEED ZONE

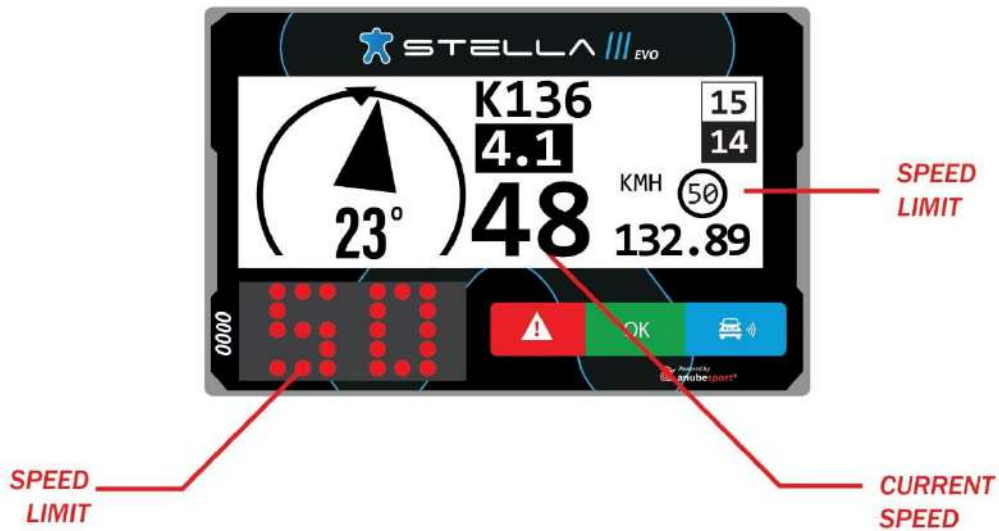

## REQUEST MEDICAL ATTENTION IMMEDIATELY



## REQUEST MEDICAL ATTENTION IMMEDIATELY



SOS ————— 1 sec.



## CAUTION VEHICLE STATIONARY



3 sec.

FIRE  
NEED RESCUE  
ABANDONED



## DANGER 3 !!!



ALERTING 300m before an area marked on the roadbook as "Danger 3"

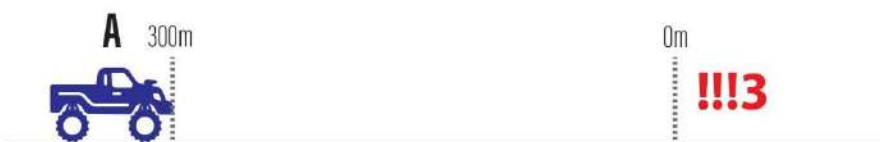

## OVERTAKING / BLUE FLAG



**FLASHING**  
Sending blue flag

**OVERTAKE  
REQUEST**



## OVERTAKING / BLUE FLAG



**GREEN**

Blue flag delivered for the vehicle ahead



**FLASHING IN BLUE**

Blue flag received from faster competitor behind



## OVERTAKING / BLUE FLAG



**OVERTAKE ACCEPTED**



**BLUE STEADY**  
The competitor must facilitate the overtaking safety

ACCEPT OVERTAKING

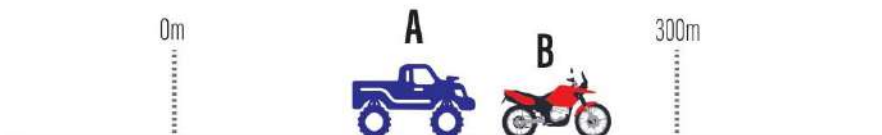

## SPEED ZONE

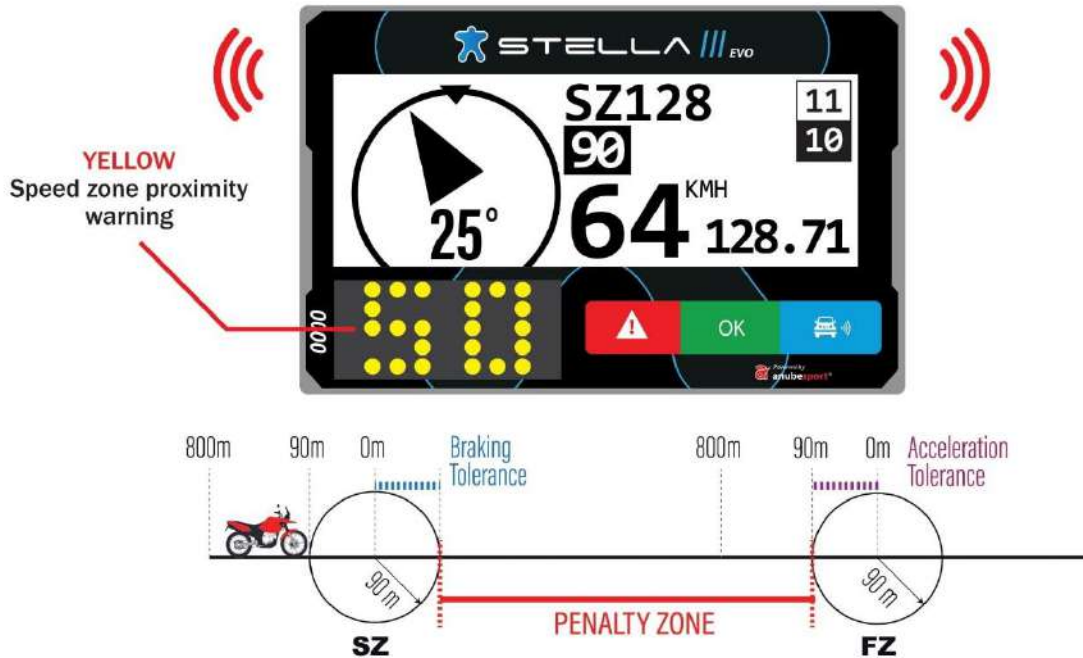

## SPEED ZONE

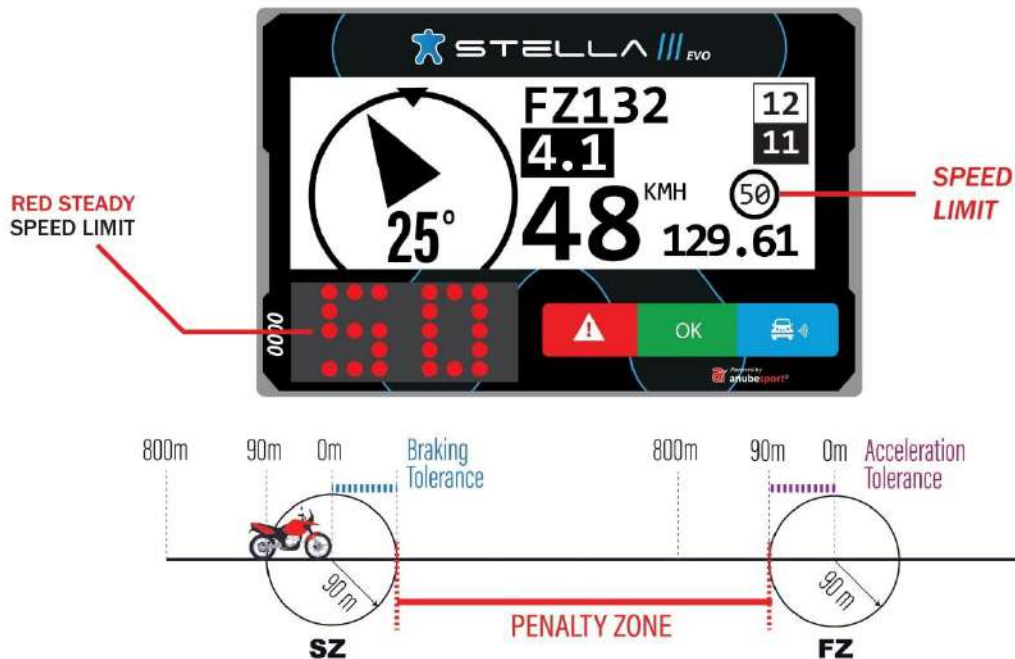



## SPEED ZONE

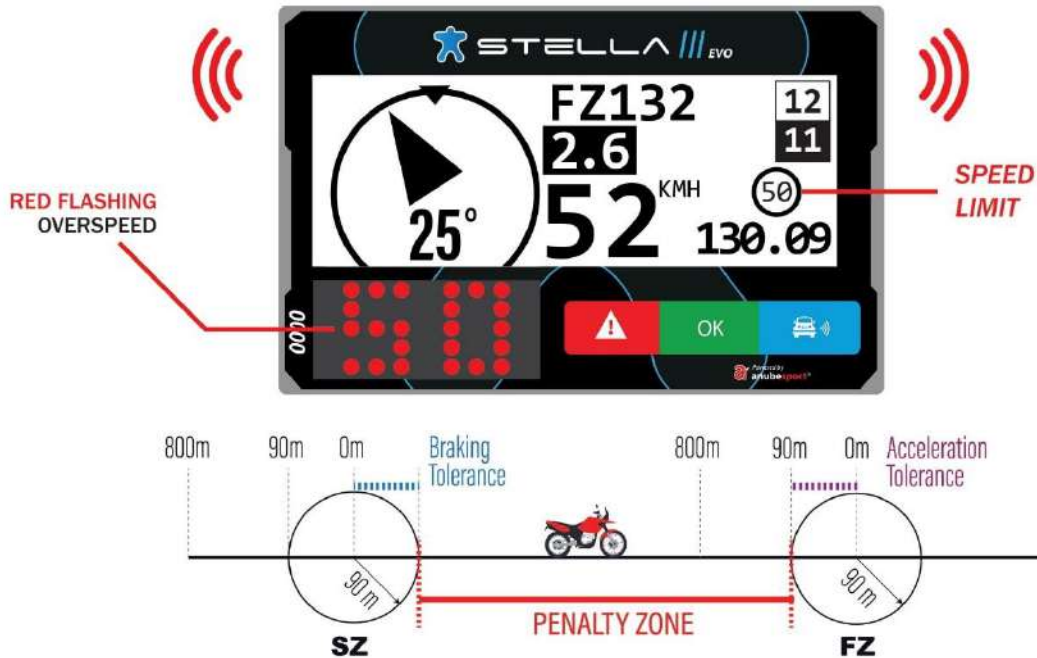

## SPEED ZONE

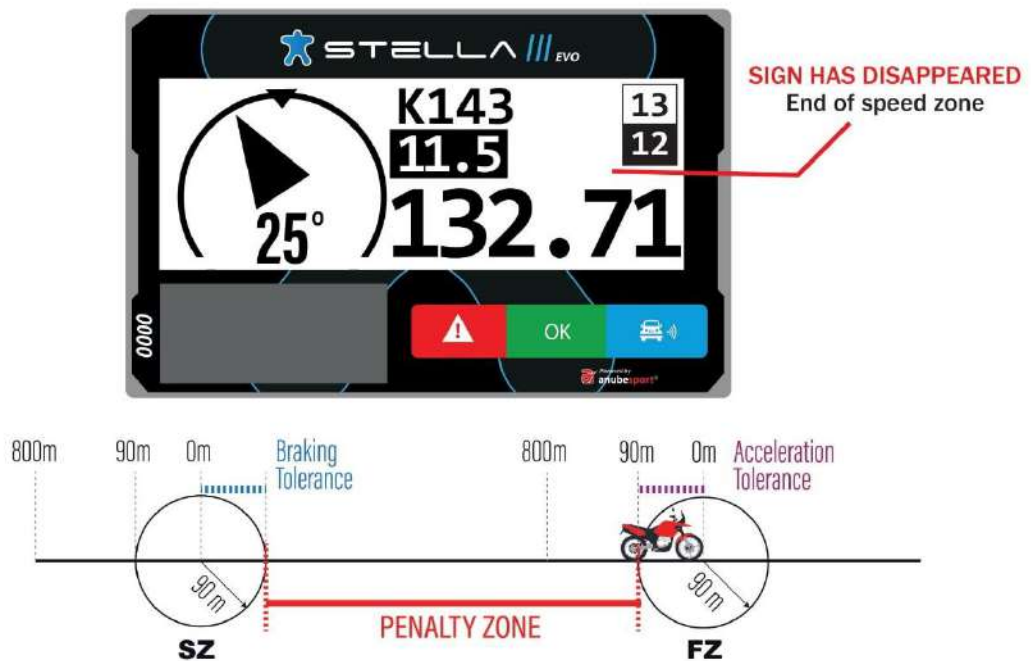

## NEUTRALIZATION ZONE

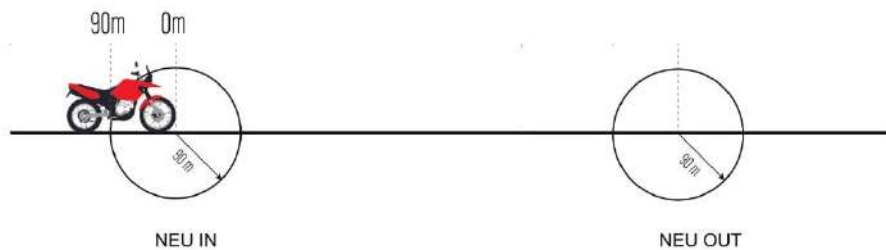

## NEUTRALIZATION ZONE

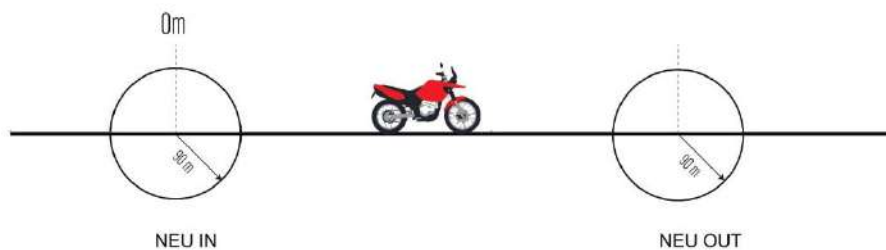

## NEUTRALIZATION ZONE

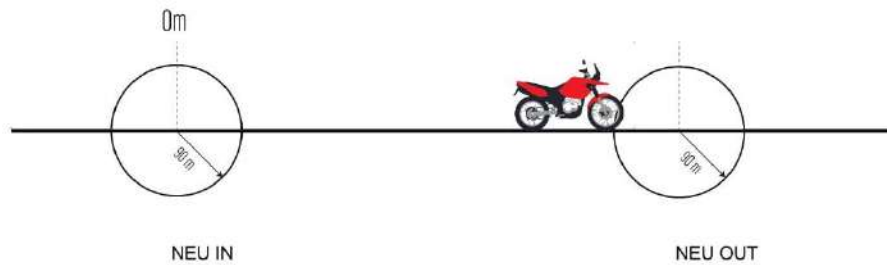

## NEUTRALIZATION ZONE

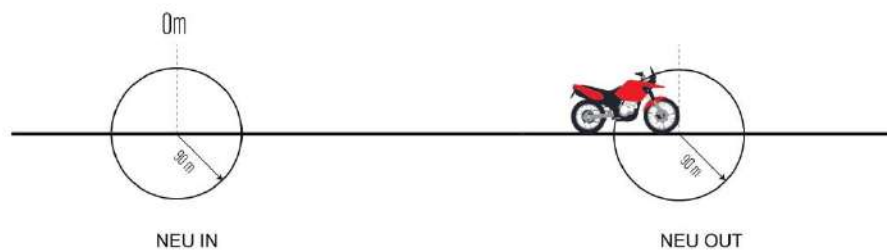

## MAXIMUM SPEED ACCORDING TO THE CATEGORY



## MESSAGES

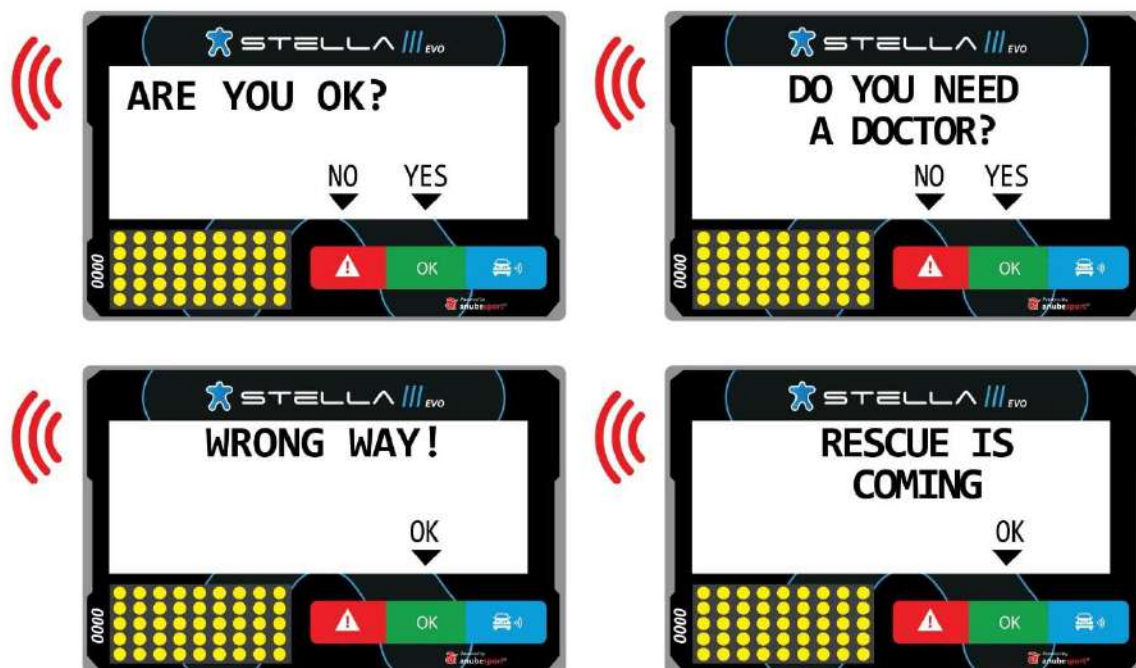

## LIST OF WAYPOINTS



OK



## SETTING TRIP TO ZERO



OK



## 20 APPENDIX 6 – NAVIGATION DEVICE INSTALLATION MANUAL



### Kit Components



1. Iridium Antenna

2. Power Cord
3. RF Cord
4. RF Antenna
5. Base/Mount
6. GPS Antenna
7. Adhesive
8. Straps
9. User Manual

## IMPORTANT

For the functional tests and verification, all vehicles must have gone through the installation of the mount, power cord, and antennas.

### 1. POWER CORD

- Connect the red wire to the positive end of the battery 12V (+), and the grey wire to the negative end (GRD). The power cord must be connected directly to the battery (without interruptions and without contact in the power supply).
- A 3A fuse (not included) should be connected to the red wire.

Take the cord to the location in which the STELLA III EVO insulated, they cannot touch

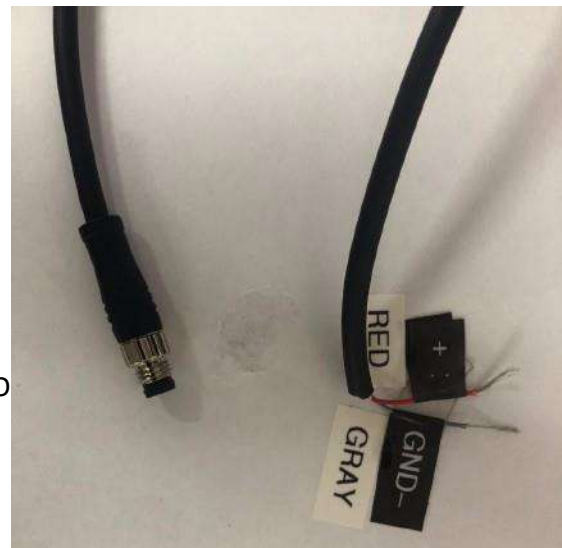

### 2. BASE/MOUNT

- Motorcycles and ATV: The mount can be attached to the handle bar or to a metal plaque close to the navigation system.
- Cars and UTV: The mount can be attached to the panel, or to the roll cage bars. STELLA III EVO buttons must be visible and accessible to the participant (pilot/navigator) even when they are sitting and with the seatbelts buckled.

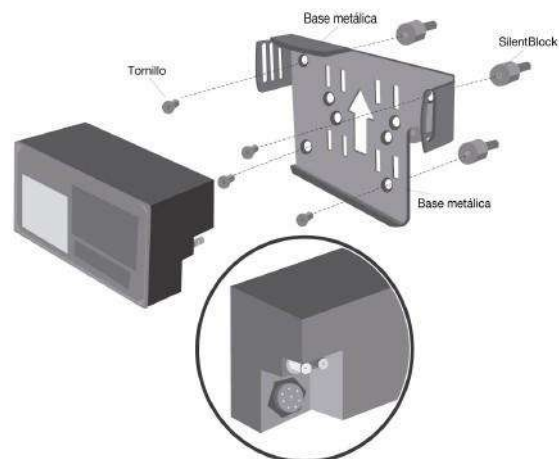

## IMPORTANT

Leave the cords (antenna and battery) in place with at least 10 cm to spare for easy handling.

At least 5 cm of space behind the mount (bottom right corner) to allow space for power cord/connections

### 3. GPS ANTENNA

The GPS antenna must be installed horizontally and without obstructions toward the sky. In cars and UTV, It can be mounted on the roof, the hood, or the dashboard. In motorcycles and ATV, attach to the mudguard. For additional firmness, it is recommended to cover it with adhesive tape (nonmetallic when mounting it to a metallic surface) and pull-up (when attached to soft or plastic parts).



### 4. ANTENNA IRIDIUM

The Iridium antenna must be installed horizontally and without obstructions toward the sky. In cars and UTV, It can be mounted on the roof, the hood, or the dashboard. In motorcycles and ATV, attach to the mudguard. For additional firmness, it is recommended to cover it with adhesive tape (nonmetallic when mounting it to a metallic surface) and pull-up (when attached to soft or plastic parts).



### 5. RF ANTENNA

The radio-frequency antenna must be





installed vertically to the roll cage bars (cars and UTV) and the forks (motorcycles and ATV). It is mandatory to use separators (included in the kit) to avoid contact with metallic parts and the carbon fiber that surrounds it.

Once the antennas are mounted, take the SMA connection cords to the base/mount where the STELLA III EVO will be installed.

## INSTALLATION EXAMPLES



### Wrong Way



## 21 APPENDIX 7 – START LIGHT PROCEDURE

### Special Stage Start

The startclock in the Special Stage start shows the minutes and seconds in 4 digit.

The second counts 00 - 59 in every minutes.

5 red light switch on one by one in every second from 55 - 59.



All the light turn green at 00.

Start before the green is a jump start.

## 22 APPENDIX 8 – EQUIPMENT & SAFETY

### 22.1 Medical equipment - Appendix III Art. 1 of the 2022 FIA (CCRSR)

Medical equipment must be placed inside the cockpit in a fluorescent coloured bag and should be easy to access for the driver and the co-driver. Its location should be clearly indicated by an orange arrow on the car.

### 22.2 Medication - information

Drivers are responsible for their medication. They have to acquire, transport and take care of it. In order to avoid legal issues (allergy risks, purchase issues, proper storage, usage, etc.), it is not provided in the survival kit.

Recommendations (to be approved by the driver's doctor):

- An analgesic (aspirin, Novalgina, paracetamol, etc.)
- Two antidiarrheal (Imodium, Bimixin or similar)
- Any personal medication or preventive medication required due to personal medical condition.

### 22.3 Compulsory: A sealed and valid medical kit in accordance with the Specification for Cross Country (FIA Technical List n°83) must be placed inside the cockpit.

- 1x rescue scissors or 1 x pair of stainless steel scissors 14.5 cm;
- 1 x adhesive plaster tape 5 m x 2.5 cm;
- 6 x sterile compresses 10 cm x 10 cm;
- 2 x sterile first aid dressing sheets 40 cm x 60 cm;
- 2 x rolls of conforming elastic self-adherent bandage Coban type or equivalent - 4 m x 8cm;
- 1 x rescue sheet - aluminium blanket 160 cm x 210 cm;
- 2 x finger plasters 12 cm x 2 cm;
- 4 x pairs of disposable nitrile gloves (adult size);
- 2 x wet wipes;
- Minimum 3 single doses of physiological saline for eyes;
- 1 x skin disinfectant (50 ml);
- 2 x compression bandages: emergency haemostatic compression pad;
- 1 x Guedel airway tube (Guedel Tubus), medium size;
- 2 x tourniquets (one-handed operation) – CAT or similar;
- 1 x chest seal, adhesive and sterile, for thoracic wounds – SAM or similar;
- 1 x information sheet;
- 1 x emergency procedure sheet;
- 1 x critical burn kit for face and hands – Water-Jel or equivalent;
- 1 x 50 ml sunscreen.

#### 22.4 Survival equipment - Appendix III Art. 2 of the 2022 FIA (CCSR)

It is compulsory for every team to carry the following equipment on board the vehicles (in addition to the seat belt cutters, the emergency communication device, the motorcycle/work goggles, the safety vest and the beacon, which are already mandatory – concerning the beacon, it is provided by the Organisation through Stella device using the SOS button as mentioned in appendix 5; pressing the SOS with no safety reasons might lead to disqualification from the competition as well as a pecuniary & cash penalty imposed upon the driver in case of Organisation intervention.

- 1 x reflective triangle;
- 1.5 litres of non-alcoholic beverages per person with Camelbak® tubes and mouthpieces or similar to facilitate drinking during the race;
- 1 x safety light (flashing torch), Powerflare® or similar;
- 1 m x 9 m towing belt;
- 1 fire ignition source: a lighter, for example;
- 1 x emergency mirror;
- 1 x headlamp, minimum 1000 lumens with extra batteries;
- warm clothes and shoes if the event is taking place in temperatures below 5°C
- Survival food supplies, 1500 calories per person (e.g. PowerBar® or similar);
- A reserve of 5 litres of water in a tank which must be easily accessible without using any tools;
- 1 x small hand shovel;
- 1 x hand compass;
- Additional 1.5 litres of non-alcoholic beverages per person with Camelbak® tubes and mouthpieces or similar to facilitate drinking during the race;

The medical and survival equipment may be checked by the Scrutineers at any time.

Any team that fails to bring this complete survival kit to the start (medical and survival equipment) will be refused to start by the Clerk of the Course until it is brought into conformity and will be subject to a penalty up to that of disqualification in the event of a repeat offence, upon decision of the Stewards.

The medical kit shall be considered for the vehicle minimum weight the survival does not.

#### 22.5 Organizer safety measures

##### **Bivouac Camp**

The organisers will provide the essential hygiene facilities

##### **Medical Services**

Fully trained doctors and nurses will be on duty throughout the event to cope with emergency situations. All local hospitals in the vicinity will be alerted to receive casualties. A medically equipped helicopter, with trained medical person on board, will be available during the event.

## 23 APPENDIX 9 – SUMMARY OF PENALTIES

Infringement	Article No.		By Stewards		By CoC				
			Stewards Decision	Disqualification	Start Refused	Section Penalty	LEG Penalty	Time Penalty	Financial Penalty (€)
Competitor not reporting accidents	SR	5.7	X						
Reporting outside the schedule for Admin Checks (max 15min)	SR	9.2	X						15/min
Reporting outside the schedule for Scrutineering (max 15min)	SR	10.1							15/min
Tampering, manipulating or interfering with the Tracking device.	SR	10.5	Max Discq						
Failing to comply with ADR requirements	SR	10.5.5	X						
Refusal to equip the vehicle with the organizer OBSC	SR	10.5.6	X		X				
No windscreen, and not wearing Goggles or a Full Helmet with visor at start of LEG	SR	10.8			X				
Not attending the compulsory drivers Briefing	SR	11.2							150
More than 30 minutes late at Prestart Hold	SR	11.3							150
Exceeding Speed Control Zone Limit	SR	11.7.2					X		X
Not Communicating withdrawal from Rally	SR	11.7.3							150
Maximum permitted lateness at TC	SR	11.7.4				X		1 h	
Environmental Mat	SR	11.18.4	X						150
Garbage Bins	SR	11.18.5							150
Infringements of Service Park/Refuel rules	SR	11.18.8	X						
Fake SOS			X		X				
Less Than 51% way points achieved in Leg 2			X						
GPS/NAV not in operational	CCRSR	12.3.2	X					15 m	
Loss of Timecard	CCRSR	14.3.4						10 m	
Absence or wrongly affixing of compulsory / optional advertising: 1 <sup>st</sup> offence (percent of entry fees)	CCRSR	20.3 V2							10%
Absence or wrongly affixing of compulsory / optional advertising: any repeated offences (percent of entry fees)									100%
Name of driver & co-driver not in compliance (percent of entry fees)	CCRSR	21.3							10%
Wrist Band/Bracelet lost (percent of entry fees)	CCRSR	21.3							10%
Vehicle not passing Scrutineering			X						
Absence of marks & seals	CCRSR	24.1.3	X						
Maximum lateness at a start	CCRSR	31.2			X	X	X		

Infringement	Article No.		By Stewards		By CoC				
			Stewards Decision	Disqualification	Start Refused	Section Penalty	LEG Penalty	Time Penalty	Financial Penalty (€)
If Crews did not check in in the correct sequence of controls and in the direction of the event route:	CCRSR	35.4.2						10 m	
- 1 <sup>st</sup> infringement: 10 minutes,								1 h	
- 2 <sup>nd</sup> infringement: 1 hour,							X		
- 3 <sup>rd</sup> infringement: disqualification									
Exceeding Control Zone speed	CCRSR	37.2.6						10sec	
- Between 1 and 5 kph (sec/pulse)								1 m	50
- Between 6 and 15 kph (min/pulse)								2 m	100
- Between 16 and 40 kph (min/pulse)								5 m	300
- More than 40 kph 1 <sup>st</sup> pulse								10 m	500
- More than 40 kph 2 <sup>nd</sup> pulse								15 m	700
- More than 40 kph 3 <sup>rd</sup> pulse									
- Any further pulses over 40kph			X						
Diff. between check-in time and target check-in time	CCRSR	38.2.10						10sec	
- Late arrival (per minute or fraction)								1 m	
- Early arrival (per minute or fraction)									
Start delay by crew at TC (per minute or fraction)	CCRSR	42.4.1						1 m	
Refusing to start SS at the allocated time	CCRSR	42.4.2						1 h	
Fails start within 20 seconds of the starting signal.	CCRSR	42.4.3						2 m	
Vehicle did not start SS	CCRSR	42.4.4					X		
False start made before the signal has been given	CCRSR	42.5						1 m	
- 1 <sup>st</sup> offence								3 m	
- 2 <sup>nd</sup> offence								10 m	
- 3 <sup>rd</sup> offence									
- Further offences			X						
Non-validation of a WPE waypoint (for each waypoint)	CCRSR	43.1.6						15 m	
Stopping between the yellow warning signs and the STOP signs is forbidden	CCRSR	44.1.2						15 m	
A competitor who does not stop at the stop point to have his times entered	CCRSR	44.2.3						1 h	
A vehicle towed or pushed through a time control	CCRSR	44.2.4							
Competitor not assisting in case of an accident	CCRSR	48.4.5	X						
Exceeding max. time allowed for SS (+missing WP + TC)	CCRSR	49.1 V2					X		

Infringement	Article No.		By Stewards		By CoC				
			Stewards Decision	Disqualification	Start Refused	Section Penalty	LEG Penalty	Time Penalty	Financial Penalty (€)
Exceeding max. permitted lateness at TC's or not checking in one or more TC (penalty/TC)	CCRSR	49.2 V2			X	X	X	1 h	
- @ Start TC of each LEG								1 h	
- @ The final TC of LEG 1				X					
- @ The final TC of LEG 2								1 h	
Reporting late for the start of a Leg if exceeding 30 min							1 h		
Parc Fermé: delay beyond the original start time (per minute or fraction, max 30 min)	CCRSR	58.7.3						1 m	
The itinerary and the road direction diagrams in the road book must be followed.			X						
Any crew refusing to start a selective section at the time and in the position allocated to it			X						

The Stewards may impose further penalties not mentioned above.





The banner features a purple and pink abstract background. In the top left corner is the Sportity logo, a blue square with a white stylized 'S'. To its right is the word 'Sportity' in a white, elegant script font. Below the logo and name, the text 'For direct event information please download the Sportity app and insert this password:' is written in white. A large white rounded rectangle in the center contains the password 'ASEER22' in bold black capital letters. At the bottom left, the website 'www.sportity.com' is listed. On the bottom right, the text 'Sportity app is available in' is followed by two app store logos: 'Available on the App Store' and 'Get it on Google play'. Below each logo is a QR code for scanning.

 Sportity

For direct event information please download the Sportity app and insert this password:

**ASEER22**

www.sportity.com

Sportity app is available in

Available on the App Store

Get it on Google play